

**FSH Rules 2012**  
**V1.1**



**FORMULA  
STUDENT  
HUNGARY**

## Document history

VERSION	DATE	MODIFICATION	PAGE
v1.0	31/01/12	-	
v1.1	03/02/12	Accommodation needs deadline added	p.8
		Registration fee was missing VAT information	p.9
		VAT details added	p.9

## 2012 Formula Student Hungary Rules

Table of Contents PART A - ADMINISTRATIVE REGULATIONS	
ARTICLE 1: FORMULA STUDENT OVERVIEW AND COMPETITION.....	4
ARTICLE 2: THE 2012 FORMULA SAE SERIES.....	6
ARTICLE 3: FORMULA SAE RULES AND ORGANISER AUTHORITY.....	6
ARTICLE 4: INDIVIDUAL PARTICIPATION REQUIREMENTS.....	6
ARTICLE 5: SAFETY RESPONSIBLE AND SAFETY ADVISOR.....	7
ARTICLE 6: VEHICLE ELGIBILITY.....	8
ARTICLE 7: REGISTRATION.....	8
ARTICLE 8: VEHICLE DOCUMENTATION, DEADLINES AND PENALTIES.....	9
ARTICLE 9: PROTESTS.....	13
ARTICLE 10: QUESTIONS ABOUT THE FORMULA SAE RULES.....	13
B - TECHNICAL REGULATIONS.....	
ARTICLE 1: VEHICLE REQUIREMENTS & RESTRICTIONS.....	14
ARTICLE 2: GENERAL DESIGN REQUIREMENTS.....	14
ARTICLE 3: DRIVER'S CELL.....	14
ARTICLE 4: COCKPIT.....	14
ARTICLE 5: DRIVERS EQUIPMENT (BELTS AND COCKPIT PADDING).....	15
ARTICLE 6: GENERAL CHASSIS RULES.....	15
ARTICLE 7: BRAKE SYSTEM.....	15
ARTICLE 8: POWERTRAIN.....	16
ARTICLE 9: FUEL AND FUEL SYSTEM.....	17
ARTICLE 10: EXHAUST SYSTEM AND NOISE CONTROL.....	17
ARTICLE 11: ELECTRICAL SYSTEM (<40V) and SHUTDOWN SYSTEM.....	18
ARTICLE 12: AERODYNAMIC DEVICES - as per 2012 FSAE Rules.....	19
ARTICLE 13: COMPRESSED GAS SYSTEMS AND HIGH PRESSURE HYDs.....	19
ARTICLE 14: FASTENERS.....	20
ARTICLE 15: TRANSPONDERS.....	20
ARTICLE 16: VEHICLE IDENTIFICATION.....	20
ARTICLE 17: EQUIPMENT REQUIREMENTS.....	21
ARTICLE 18: Possible Future Rules Changes.....	21
ARTICLE 19: HIGH VOLTAGE ELECTRICAL SYSTEMS.....	21
ARTICLE 20: VEHICLE CONTROL SYSTEMS.....	30
ARTICLE 21: REQUIREMENTS OF THE (ELECTRICAL) SAFETY FORM.....	32
ARTICLE 22: ADDITIONAL SAFETY REQUIREMENTS.....	33
FS Appendix B1 - Wire Current Capacity (DC).....	35
FS Appendix B2 - Required Equipment for Vehicles with HV Electrics.....	36
FS Appendix B3 - Recommended Standards.....	37
PART C - STATIC EVENT REGULATIONS.....	
ARTICLE 1: STATIC EVENTS, MAXIMUM SCORES+BUSINESS LOGIC CASE.....	38
ARTICLE 2: TECHNICAL INSPECTION.....	39
ARTICLE 3: COST, MANUFACTURING AND SUSTAINABILITY EVENT.....	40
ARTICLE 4: BUSINESS PRESENTATION EVENT.....	53
ARTICLE 5: DESIGN EVENT.....	55
FS Appendix C1 - Sustainability - Powertrain assemblies.....	61
PART D - DYNAMIC EVENT REGULATIONS.....	
ARTICLE 1: DYNAMIC EVENTS AND MAXIMUM SCORES.....	62
ARTICLE 2: WEATHER CONDITIONS.....	62
ARTICLE 3: RUNNING IN RAIN.....	62
ARTICLE 4: DRIVER LIMITATIONS.....	62

ARTICLE 5: ACCELERATION EVENT .....	62
ARTICLE 6: SKID-PAD EVENT .....	62
ARTICLE 7: AUTOCROSS EVENT (known and SPRINT EVENT in UK).....	62
ARTICLE 8: ENDURANCE AND FUEL ECONOMY .....	62
ARTICLE 9: FLAGS .....	64
ARTICLE 10: RULES OF CONDUCT .....	64
ARTICLE 11: GENERAL RULES.....	66
ARTICLE 12: PROTESTS.....	66
ARTICLE 13: PIT RULES.....	66
ARTICLE 14: DRIVING RULES .....	66
ARTICLE 15: DEFINITIONS .....	66

Note: All references made to specific regulations, refer to these regulations unless they explicitly refer to the FSAE regulations.

## 2012 Formula Student Hungary Rules

### PART A - ADMINISTRATIVE REGULATIONS

#### ARTICLE 1: **FORMULA STUDENT HUNGARY OVERVIEW AND COMPETITION - as article 1 from 2012 FSAE Rules except**

Formula Student Hungary permits students to compete with running vehicles built to the FSAE or Formula Student rules.

Competition date and place: August 17, 2012 to August 20, 2012

Formula Student Hungary (FSH) will take place in 9181 Győr-Károlyháza, Kikötő I. (Győr-Gönyü Harbor)

GPS: coordinates:        **+47° 43'57.07"**  
                                      **+17°46'16.83"**

#### **A1.1 Formula Student Hungary Objective and Regulations**

The Formula Student Hungary competition embodies the same objectives as The Formula SAE® Series (see 2012 FSAE Rules A1.1) but it also allows the development of alternatively fuelled vehicles.

*A1.1.1 For the first time in 2012, Formula Student Hungary will allow vehicles built to the FSAE rules to compete directly against those built to what were previously called the Formula Student Class 1A rules (for alternatively fuelled vehicles), with the exception, that Formula Student Hungary will only accept electric powered alternative vehicles in 2012. Any vehicle which is solely powered by Petrol (Gasoline) or E-85 must be manufactured to comply exactly with the 2012 FSAE regulations. Vehicles built using electric powertrains (not solely Petrol or E-85) must also comply exactly with the 2012 FSAE rules except for the specific regulations as identified in this document. Note: there are some regulations in this rule book that will be applied to all vehicles, eg.sustainability and fuel economy/CO2 production.*

**A1.1.2** An overview of the main regulation differences *for those vehicles using electric powertrains* is as follows:

*For electric powertrain vehicles will compete directly against all conventional combustion engine vehicles.*

- a. *During the endurance event the fuel economy of all vehicles will be measured in terms of the production of CO<sub>2</sub> measured in kg. The quantity of CO<sub>2</sub> released to the atmosphere by the consumption of each allowable fuel will be specified in the rules and is intended to represent the EU average number for the type of fuel under consideration.*
- b. *In addition to the cost event, a sustainability section will be added that will evaluate the embedded CO<sub>2</sub> and energy in the vehicle powertrain of all vehicles.*
- c. *In 2012, any combustion engine must use a 4 stroke cycle engine with a maximum capacity of 610cc.*
- e. Allowable Power Sources - The allowable forms of power are specified as Petrol, E85, or Electric and no combinations of these to form a hybrid.

- f. There are significant additional regulations describing and relating to the powertrain including the requirements for drive-by-wire systems and HV electrical systems. *For those teams that choose an electric vehicle solution, the regulations will wherever possible enable them to compete in Formula Student UK and Formula Student Electric.*

## A1.2 Vehicle Design Objectives

For the purpose of the Formula Student Hungary competition, teams are to assume that they work for a design firm that is designing, fabricating, testing and demonstrating a prototype vehicle for the non-professional, weekend, competition market.

- A1.2.1 *The vehicle may* adopt electric powertrain technologies such that it is high performance, whilst the amount of CO<sub>2</sub> it emits is as low as feasibly possible and the CO<sub>2</sub> and energy embedded in the vehicle is minimised. Recyclability must also be considered in the design.
- A1.2.2 The vehicle should have high performance in terms of acceleration, braking and handling and be sufficiently durable to successfully complete all the events described in the Formula Student /FSAE Rules and held at the Formula Student Hungary competition.
- A1.2.2 The vehicle must accommodate drivers whose stature ranges from 5<sup>th</sup> percentile female to 95<sup>th</sup> percentile male and must satisfy the requirements of the Formula SAE Rules.
- A1.2.3 Additional design factors to be considered include: aesthetics, cost, ergonomics, maintainability, manufacturability and reliability.
- A1.2.4 Once the vehicle has been completed and tested, your design firm will attempt to “sell” the design to a “corporation” that is considering the production of a competition vehicle. The challenge to the design team is to develop a prototype car that best meets the Formula Student Hungary vehicle design goals and which can be profitably marketed.
- A1.2.5 Each design will be judged and evaluated against other competing designs to determine the best overall car.

## A1.4 Judging Categories

The cars are judged in a series of static and dynamic events including: technical inspection, sustainability, presentation, and engineering design, solo performance trials, and high performance track endurance.

- A1.4.1 The dynamic events are scored to determine how well the car performs. Each dynamic event has specified minimum acceptable performance levels that are reflected in the scoring equations.

The following points are possible:

### Static Events:

Business Presentation	75
Engineering Design	150
Cost and Sustainability	100

### Dynamic Events

Acceleration	75
Skid-Pad	50
Autocross	150
Fuel Economy/CO <sub>2</sub> emissions	100
Endurance	300
<b>Total Points</b>	<b>1,000</b>

**ARTICLE 2: THE 2012 FORMULA SAE SERIES - as per 2012 FSAE Rules**

**ARTICLE 3: FORMULA SAE RULES AND ORGANISER AUTHORITY - as per 2012 FSAE Rules**

**ARTICLE 4: INDIVIDUAL PARTICIPATION REQUIREMENTS**

**A4.1 Eligibility Limits**

Eligibility is limited to undergraduate and graduate students to insure that this is an engineering design competition.

**A4.2 Student Status**

Team members must be enrolled as degree seeking undergraduate or graduate students in a college or university. Team members who have graduated during the seven (7) month period prior to the competition remain eligible to participate.

**A4.3 Society Membership**

A4.3.1 Every participating team member must be a member of one of the FISITA ([www.fisita.org](http://www.fisita.org)) engineering societies.

**A4.4 Age**

Team members must be at least eighteen (18) years of age.

**A4.5 Driver's Licence**

Team members who will drive a competition vehicle at any time during a competition must hold a valid, government issued driver's license or a recognised (ASN) approved karting or car motorsport licence.

**A4.6 Liability Waiver**

All on-site participants, including students, faculty and volunteers, are required to sign a liability waiver upon registering on-site.

**A4.7 Medical Insurance**

All team participating members must have valid and suitable medical insurance.

**A4.8 Individual Registration Requirements for Formula Student Hungary**

A4.8.1 Team Leaders must ensure that every participant's, including Faculty Advisors, name is listed on their team's online Team Details account page on the FSH website.

**A4.8.2 Onsite Registration Requirement**

ONSITE REGISTRATON IS REQUIRED OF ALL TEAM MEMBERS AND FACULTY ADVISORS.

All FSH car drivers must bring their government issued driver's license to onsite registration.

**ARTICLE 5: SAFETY RESPONSIBLE AND SAFETY ADVISOR** Note teams also require a faculty advisor as described in Article 5 of the 2012 FSAE regulations.

**A5.1 Requirement for a *safety responsible and safety advisor***

A5.1.1 The intent of the FSAE regulations, when correctly followed is to ensure that wherever possible the cars are fundamentally safe. This is achieved by applying strict regulations relating to the vehicle layout and the design of key components. For the new technologies that are embraced by cars built with electric powertrains, setting of regulations to ensure complete safety of a wide range of electric powered vehicles is difficult. For this reason the safety of *electric powertrain* vehicles must be ensured by using a professionally competent person(s) nominated by the Entrant *who can advise on the safety systems to do with the HV electrical configuration and the control systems*. This competent person(s) will be designated the Safety Advisor.

*In addition a safety responsible person will be required who is responsible for the safe operation of the vehicle at the event. This person may be an experienced student team member who has received adequate training on all safety critical items.*

**A5.2 Requirements of the *safety responsible and safety advisor***

A5.2.1 All entries *with electric powertrains* must be accompanied by a form that specifies the people who are responsible for the safety of the car (The Safety Advisor or SA and the Safety Responsible SR). The SA must supply a resume detailing their experience in the field of technology employed by the car. His or her acceptability as an SA needs to be approved by the organisers before the entry is accepted. It is likely that the SA will be a Chartered Engineer or someone of equivalent status.

*The SR must submit a resume of the relevant training that has been undertaken.*

A5.2.2 The SA must have significant experience of the technology that is being developed and its implementation into vehicles or other safety critical systems such that they are adequately qualified *to advise the team on their proposed electrical and control system designs*. Note: It may be necessary to have more than one person to achieve this requirement.

A5.2.3 *The SA must advise the team such that the merits of any relevant engineering solutions can be discussed, questioned and approved before being implemented into the final vehicle design.*

A5.2.4 The SA must advise the students on the required training such that they are competent to work with the systems on the vehicle.

A5.2.5 The SA(s) must sign the electrical safety form and FMEA documents to confirm that the vehicle encompasses good engineering practices.

A5.2.6 *The SR(s) is responsible for every kind of work on the car during the event and must declare the car to be electrically safe before any work on any system of the car may be performed.*

A5.2.7 The SR(s) must be present at the competition during scrutineering and whenever the car runs.

A5.2.8 *The SR(s) must be contactable by phone at all times during the event.*

A5.2.9 *The SR(s) may only be a driver if at least two SRs are nominated by the team.*

**A5.3**

### **Unusual aspects of the design**

A5.3.1 The SA must ensure that the team discusses any unusual aspects of the design with the rules committee to reduce the risk of exclusion or significant changes being required to pass scrutineering.

### **ARTICLE 6: VEHICLE ELIGIBILITY - as per 2012 FSAE Rules except for the following**

#### **A6.9 Second Year Vehicles**

A6.9.1 Second year vehicles are not allowed

### **ARTICLE 7: REGISTRATION**

#### **A7.1 Registration**

Start: February 10, 2012 at 12:00 CET

Registration for Formula Student Hungary must be completed on-line.

Registration forms will be accepted in the order in which they are received, starting February 10, 2012 at 12:00 CET and ending on April 30, 2012 12:00 CEST or when the registration limit is reached. Registration will be online at the FSH Website. ([www.fshungary.hu](http://www.fshungary.hu))

**NOTE: You have to designate ALL team members during the registration process. Later you will NOT have the possibility to buy additional tickets for team members, but you will be able to switch designated team members and modify accommodation needs until July 15.**

**Your registration is only valid after you pay the registration fee. You can start uploading your documents after your registration is valid.**

#### **A7.2 Entries per University**

Registration for Formula Student Hungary is limited to one (1) vehicle per University per powertrain type. It is important, that in the teams have to be separate organizations.

#### **A7.3 Registration Limits**

Registration for the Formula Student Hungary is limited to 40 cars. There are 10 slots reserved for teams which have electric vehicles. If there would be some open slots at the end of the registration period, then all open slots will be filled up with petrol cars from the waiting list.

The **overall top 3 teams** from FSH 2011 will have a registration priority as far as they send a pre application e-mail to the [pre-app@fshungary.hu](mailto:pre-app@fshungary.hu) address before February 9, 2012 12:00 CET.

Overall Top 3 teams are:

- Metropolia Motorsport
- KA-RaceIng e.V.
- HAWKS Racing e. V.

**The winner of the 2011 GTE Special Award has a reserved registration slot and its registration fee will be paid by GTE, this is a part of the award.**

**The 2011 GTE Special Award winner is: Racetech Racing Team TU Bergakademie Freiberg e.V.**

**A7.4 Registration Dates**

Registration is starting February 10, 2012 at 12:00 CET and ending on April 30, 2012 12:00 CEST or when the registration limit is reached

**A7.6 Registration Fees**

A7.6.1 The registration fee of 750 Euros+VAT is for one 20-person team. More team members can be registered for 25 Euros per each additional team member. There is no limit to team size.

The teams have to pay the registration fee via bank transfer within 10 days from the team's registration date. Every team will get an invoice via e-mail shortly after the event registration. It is important to fill out all your invoice information in your team account, if one information is missing, we will not be able to send you an invoice.

**Important information:**

Account holder: X-Meditor Kft. – 9023 Győr, Csaba utca 21. Hungary

Bank account number: 11763378-41901881

IBAN: HU83 1176 3378 4190 1881 0000 0000

BIC (SWIFT) Code: OTP VHUHB

The teams have to pay the registration fee via bank transfer within 10 days from the team's registration date. You have to pay the transfer fee (approximately 0,05 %), this you have to tell your bank before transferring. Every team will get an invoice via e-mail shortly after the event registration.

It is important to fill out all your invoice information in your team account, if any information is missing, we will not be able to send you an invoice.

*We also need to know your European VAT number (if you are from a not European country, then your local VAT number)!*

You can provide both numbers as team profile data. VAT has to be paid according to Hungarian tax rules in the following cases:

- The team is from an EU country and has no EU VAT number
- Your team has either local or EU VAT number
- The team organisation is Hungarian

A7.6.2 Registration fees are not refundable and may not be transferred to a subsequent year's competition.

**A7.7 Withdrawals**

A7.7.1 Registered teams that find that they will not be able to attend the competition are requested to officially withdraw by notifying the following as soon as possible:

A7.7.2 Formula Student Hungary Event withdrawals: Zsolt Bojkovszky:  
b.zsolt@fshungary.hu

**A7.8 Joint Entries**

A joint entry by two institutions is allowed. Therefore, two universities or a university and a technical college can enter a class under the name of one of the institutions. There MUST be at least one Faculty Advisor responsible for supervising the joint project.

**ARTICLE 8: VEHICLE DOCUMENTATION, DEADLINES AND PENALTIES -  
penalties as per 2012 FSAE Rules, except as shown below.**

**A8.1 Required Documents and Required Forms**

The following documents supporting each entry must be submitted by the action deadlines posted on each competition website or otherwise published by the organizers.

Note: Any upload which does not contain a substantial amount of the required information shall be deemed to be a non-submission and the appropriate penalties will be applied.

FSAE rules B3.8 "**Structural Equivalency Spreadsheet (SES)**" and **FSAE rules Appendix B-1** - Use required form located at [www.fsaonline.com](http://www.fsaonline.com): - Use required form located at [www.fsaonline.com](http://www.fsaonline.com).

*Note - All Teams must submit an SES*

FSAE rules B3.21 "**Impact Attenuator Data Requirement**" - Use required form located at [www.fsaonline.com](http://www.fsaonline.com).

B9.1 "**Fuel**" - A fuel type order will be required via the team account at the FSH website- You must inform FSH which type of fuel you will use no later than **July 25, 2012** at 12:00 CEST.

B21.4 - For any vehicle that uses an electric power train, eg. an electric vehicle, an **Electrical Safety form** must be submitted

C1.3 "**Business Logic Case**" - A business logic case must be submitted by all teams and must comply with the Business Logic Case Rules

C3.8 "**Cost Report**" - Report must comply with the Cost Event Rules. Both an electronic version and a hard copy version are required.

The written Report must arrive at the address listed below, no later than the specified date.

Mr. Alexander Dudás  
Formula Student Hungary  
Csaba u. 21.  
9023 Győr  
Hungary

The parcel or envelope used must be clearly labelled with the Senders University Name and FSH assigned Car Number.

C5.2 "**Design Report**" - Report must comply with the Design Event Rules

C5.5 "**Design Spec Sheet**" - Use required form located at <http://www.fshungary.hu>

C5.7 "**Student Activity Disclosure Form**" - Use required form located at [www.fsaonline.com](http://www.fsaonline.com).

"**Health Insurance Certificate**" – upload to FSH website

Program Submissions - Material required for programmes is specific to each competition. Please check the FSH website for details.

## **A8.2 Deadlines**

Volunteer judges evaluate all the required submissions and it is essential that they have enough time to complete their work. There are no exceptions to the document submission deadlines and late submissions will incur penalties.

**Structural Equivalency Spreadsheet (SES) and FSAE rules Appendix B-1:  
June 1, 2012, 12:00 CEST**

**Impact Attenuator Data Requirement: June 1, 2012, 12:00 CEST**

**Electrical Safety form: June 1, 2012, 12:00 CEST**

**Business Logic Case: June 30, 2012, 12:00 CEST**

**Cost Report: June 30, 2012, 12:00 CEST**

**Design Report: June 30, 2012, 12:00 CEST**

**Design Spec Sheet: June 30, 2012, 12:00 CEST**

**Student Activity Disclosure Form: June 1, 2012, 12:00 CEST**

**Health insurance certificate: July 25, 2012, 12:00 CEST**

## **A8.3 Submission Addresses and Formats**

The procedure for submitting documents is outlined on the FSH website. Addresses to which the various documents should be sent are published on the FSH website. Most required documents must be submitted in the specified format. Failure to submit a document in the proper format, or with an incorrect file name, may be considered as "Not Submitted."

Carefully read the event rules and check the website. There may be a few days delay between your log in to the website being validated and your ability to upload document submissions: do not leave it to the last minute!

## **A8.4 Late Submission Penalties**

Documents received /uploaded after the deadline will be penalized negative ten (-10) points per day, or partial day, late with the following penalty caps and exclusions:

FSAE rules B3.8.5 "Structural Equivalency Spreadsheet (SES)" or AF2 "Structural Requirements Certification Form (SRCF)" - The penalty for late SES/SRCF submission is capped at negative fifty (-50) points.

However, teams are advised that SES/SRCF forms are evaluated in the order in which they are received and that late submissions will be reviewed last. Late SES/SRCF approval could delay the completion of your vehicle. We strongly recommend you submit your SES/SRCF as early as possible.

FSAE rules B3.21.7 "Impact Attenuator Report Penalties" - The penalty for late Impact Attenuator Report submissions is capped at negative fifty (-50) points.

B9.1 "Fuel" - There is no point penalty for late submission of a fuel type order, however once the deadline has passed your team will be allocated the basic fuel type.

B21.3 “Electrical Safety Form” - The penalty for late ESF submission is capped at negative fifty (-50) points and is applicable to any team that uses an electric powertrain (eg. an electric vehicle).

Rules C1.3 “Late Submission of the Business Logic Case” - The penalty for late Business Logic Case submissions is capped at negative fifty (-50) points.

Rule C3.15 “Late Submission of Cost & Sustainability (C&S) Report” - For the first 15 days after the deadline submission penalties for late C&S Reports are capped at negative eighty (-80) points. After the first 15 days a late C&S Report is classified as “Not Submitted”. C&S that are not submitted will receive negative one hundred (-100) points and may not participate in the Cost & Sustainability Event.

Rule C5.9 “Late Submission or Non-submission of Design Documents” The Design Report, Design Spec Sheet and Student Activity Disclosure Form collectively constitute the “Design Documents”. Late submission or failure to submit all, or any one, of the Design Documents will be penalized at the standard negative ten (-10) points per day to a maximum of negative one hundred (-100) points. If any or all of your Design Documents are received more than ten (10) days late they will be classified as “Not Submitted” and your team will receive zero (0) points for Design towards the overall score and may not participate in the Design Event. See also A8.5.

However such entrants may be judged like any other at the event in the Design competition and will receive the same feedback. At the sole discretion of the Design Event Head Judge such entrants may receive a grading indicating their potential had they in fact submitted the Design Documents by the deadline.

Note that teams that receive any such official judging or feedback from the judges will be deemed to have “competed” at the event and as such this may affect their entry eligibility for the following year, see also A6.9 and C5.16

This is only a summary; it does not supersede the event rules. Read the rules for complete document submission requirements. Check the FSH website for deadlines, submission addresses and other details. If you have any questions - ask us.

## **A8.5 Web Based Submission - Formula Student Hungary**

Teams entering Formula Student Hungary must submit the following documents online through <http://fshungary.hu>

B3.8 “Structural Equivalency Spreadsheet (SES)”

B3.21 “Impact Attenuator Data Requirement”

B21 “(Electrical) Safety Form and FMEA”

C5.2 “Design Report”

C5.4 “Design Spec Sheet”

C5.7 “Student Activity Disclosure Form”

“Health insurance certificate”

Submissions may be replaced with new uploads at any point.

Late submission penalties apply to documents uploaded after the deadline date.

Note: An “empty” template document containing zero information submitted on time will be considered an invalid submission: the intent here is to prevent late penalties being circumvented by the uploading of a blank “placeholder” within the deadlines.

**A8.6 Team Accounts**

Uploading Documents - Team Leaders are responsible for uploading all of their team’s submissions before the deadline.

Document Access - Uploaded documents can only be viewed by (1) Team Leaders, (2) authorised judges, technical inspectors and officials and (3) IMechE staff.

Reminder - The website does not know what you intended to submit or what you thought you were doing. Anything your team uploads to the site is considered to be an official action by your team.

**ARTICLE 9: PROTESTS - as per 2012 FSAE Rules**

**ARTICLE 10: QUESTIONS ABOUT THE FORMULA SAE RULES - as per 2012 FSAE Rules and in particular:**

## 2012 Formula Student Hungary Rules

### PART B - TECHNICAL REGULATIONS

**ARTICLE 1: VEHICLE REQUIREMENTS & RESTRICTIONS - as per 2012 FSAE Rules**

**ARTICLE 2: GENERAL DESIGN REQUIREMENTS - as per 2012 FSAE Rules**

**ARTICLE 3: DRIVER'S CELL - as per 2012 FSAE Rules except**  
Please note that the alternative fuels SES must be used - see FSH website

**B3.0 Vehicle Structure - 2 Options**

In 2012 Formula Student Hungary will only accept vehicles built to FSAE article 3 and not the vehicles built to the alternative frame rules

**B3.9 Main and Front Roll Hoops - General Requirements as per FSAE rules except for all vehicles**

**B.3.9.4** The 95th percentile male template will be positioned as follows: (See Figure 2.)

- The seat will be adjusted to the rearmost position.
- The pedals will be placed in the most forward position.
- The bottom 200 mm circle will be placed on the seat bottom such that the distance between the centre of this circle and the rearmost face of the rearmost pedal is no less than 915 mm (36 inches).
- The middle 200 mm circle, representing the shoulders, will be positioned on the seat back.
- The upper 300 mm circle will be positioned no more than 25.4 mm (1 inch) away from the head restraint (i.e. where the driver's helmet would normally be located while driving).
- 

**B3.9.5** If the requirements of B3.9.3 and B3.9.4 are not met with the 95th percentile male template, then a real 95th percentile male must fit correctly into the car such that the steering wheel and pedals can be reasonably operated otherwise the car will NOT receive a Technical Inspection Sticker and will not be allowed to compete in the dynamic events.

**B3.21.8 Impact Attenuator Assessment and Grading**

The impact attenuator will be assessed and grades as described in the Formula Student Hungary static event rules under Technical Inspection.

**ARTICLE 4: COCKPIT - as per 2012 FSAE Rules except the following *for cars with electric powertrains***

**B4.5 Firewall**

**B4.5.1** A firewall must separate the driver compartment from all components of the fuel supply, the engine oil, the liquid cooling systems and any energy storage systems. It must protect the neck of the tallest driver. It must extend sufficiently far upwards and/or rearwards such that any point less than 100 mm (4 ins.) above the bottom of the helmet of the tallest driver shall not be in direct line of sight with any part of the fuel system, the cooling system, the engine oil system or any energy storage system or related components.

- B4.5.2 The firewall must be a non-permeable surface made from a rigid, fire resistant material. Any firewall material must comply with the UL94-V0 flammability standard and must have a shear strength equivalent to an aluminium panel with 1.6mm thickness.
- B4.5.3 Any firewall must seal completely against the passage of fluids, especially at the sides and the floor of the cockpit, i.e. there can be no holes in a firewall through which seat belts pass.
- B4.5.4 Pass-throughs for wiring, cables, etc. are allowable if grommets are used to seal the pass-throughs. Also, multiple panels may be used to form the firewall but must be sealed at the joints.
- B4.5.5 If the car has HV electric systems then the firewall must be made from or coated in an electrically insulating material *which is both puncture and scratch resistant*.

**ARTICLE 5: DRIVERS EQUIPMENT (BELTS AND COCKPIT PADDING) - as per 2012 FSAE Rules**

**ARTICLE 6: GENERAL CHASSIS RULES - as per 2012 FSAE Rules except for all vehicles**

**B6.3 Wheels**

B6.3.3 Extended or composite wheel studs are prohibited

**B6.4 Tires**

B6.4.3 Remoulded or re-treaded tyres are prohibited

**ARTICLE 7: BRAKE SYSTEM - as per 2012 FSAE Rules except as follows for vehicles with electric powertrains**

B7.1.4 "Brake-by-wire" systems are allowed for regenerative braking as long as at least 50% of the brake travel activates a mechanical hydraulic system which meets the normal FSAE rules when the regenerative braking system is turned off.

**and as follows for all vehicles**

*B7.1.10 All brake reservoirs must be shielded from the driver with an impermeable barrier which has a thickness of at least 0.5mm.*

**B7.2 Brake Test**

The brake system will be dynamically tested and must demonstrate the capability of locking all four (4) wheels and stopping the vehicle in a straight line at the end of an acceleration run specified by the brake inspectors. *Note: if the vehicle uses regenerative braking then this feature must be disabled for the test.*

**B7.3 Brake Over-Travel Switch - additional requirements for Electric Vehicles**

B7.3.1 A brake pedal over-travel switch must be installed on the car as *part of the shutdown system and wired in series with the shutdown buttons*. This switch must be installed so that in the event of brake system failure such that the brake pedal over travels it *will result in the shutdown system being activated and controlling the systems as defined in B11.3.*

- B7.3.2 Repeated actuation of the switch must not restore power to these components, and it must be designed so that the driver cannot reset it.
- B7.3.3 The switch must be implemented with analogue components, and not through recourse to programmable logic controllers, engine control units, or similar functioning digital controllers. The implementation must be as shown in figure 2 or equivalent for vehicles with HV systems.
- B7.5 Brake Over Pressure Switch - Electric Vehicles Only**  
Formula Student Hungary is considering the requirement to have a pressure switch on the brake system such that in a panic braking event, the brake over pressure switch is tripped and the shutdown system is activated.

**ARTICLE 8: POWERTRAIN - as per 2012 FSAE Rules except as follows for *alternative powertrain vehicles***

- B8.1 Engine Limitation
- B8.1.1 If a liquid fuel burning engine is fitted it must be an Internal Combustion, four-stroke piston engine with a maximum displacement of *610cc*.
- B8.1.2 The engine can be modified within the restrictions of the rules.
- B8.5 Throttle and Throttle Actuation**
- B8.5.1 Carburettor/Throttle Body  
The car must be equipped with a carburettor or throttle body. The carburettor or throttle body may be of any size or design.
- B8.5.2 Throttle Actuation  
Only cars which are not solely powered by either petrol or E-85 may use electronic throttle control (ETC) or “drive-by-wire” systems to control the power that is delivered to the wheels, however strict regulations apply to such systems as described in Article B20.
- B8.5.3 Any throttle cable or rod must have smooth operation, and must not have the possibility of binding or sticking.
- B8.5.4 When a purely mechanical throttle is used, the throttle actuation system must use at least two (2) return springs located at the throttle body, so that the failure of any component of the throttle system will not prevent the throttle returning to the closed position.  
**Note: Throttle Position Sensors (TPS) are NOT acceptable as return springs.**
- B8.5.5 Throttle cables must be at least 50.8 mm (2 inches) from any exhaust system component and out of the exhaust stream.
- B8.5.6 A positive pedal stop must be incorporated on the throttle pedal to prevent over stressing the throttle cable or actuation system.
- B8.5.7 For all vehicles, if the throttle system contains any mechanism that could become jammed, for example a gear mechanism, then this must be covered to prevent ingress of any debris

### **B8.6 Intake System Restrictor**

- B8.6.1 In order to limit the power capability from the engine, a single circular restrictor must be placed in the intake system between the throttle and the engine and all engine airflow must pass through the restrictor.
- B8.6.2 Any device that has the ability to throttle the engine downstream of the restrictor is prohibited.
- B8.6.3 The restrictor must have a maximum diameter of:  
- Gasoline fueled cars - 20mm (0.787inch)  
- E-85 fueled cars - 19mm (0.748inch)
- B8.6.4 The restrictor must be located to facilitate measurement during the inspection process.
- B8.6.5 The circular restricting cross section may NOT be movable or flexible in any way, e.g. the restrictor may not be part of the movable portion of a barrel throttle body.

### **B8.14 Powertrain System location**

- B8.14.1 All power train system components must lie within the surface defined by the top of the roll bar and the outside edge of the four tires. (See 2012 FSAE rules Figure 13).
- B8.14.2 Any fuel, other energy storage media must be contained within the primary structure of the frame and when located less than 350mm from the ground must be protected from side or rear impacts with a structure built to Rule B3.24 or B3.31 as applicable. *The application of this rule to HV systems and HV wiring is covered by B19.13.2*

## **ARTICLE 9: FUEL AND FUEL SYSTEM - as per 2012 FSAE Rules except as follows**

### **B9.1 Fuel available at the competition**

For internal combustion engine cars built to the FSAE regulations, only unleaded gasoline fuel and E85 (bio-ethanol and gasoline blend) will be available at the event. The unleaded gasoline will have the octane rating, 99 RON (Research Octane Number). Any team wishing to use E85 fuel must declare that intention in advance . No other fuel will be available

## **ARTICLE 10: EXHAUST SYSTEM AND NOISE CONTROL - as per 2012 FSAE Rules except**

Note: In principle Electric vehicles or vehicles that do not use a combustion engine do not need a noise test. The organisers do however reserve the right to test any vehicle that is deemed to be excessively noisy using an appropriate manner.

### **B10.2.4 Test Speeds**

The test speed for a given engine will be the engine speed that corresponds to an average piston speed of 914.4 m/min (3,000 ft/min) for automotive or motorcycle engines, and 731.5 m/min (2,400 ft/min) for "industrial engines". The calculated speed will be rounded to the nearest 500 rpm. The test speeds for typical engines will be published by the organisers. An "industrial engine" is defined as an engine which,

according to the manufacturer's specifications and without the required restrictor, is not capable of producing more than 5 hp per 100cc.

To have an engine classified as "an industrial engine", approval must be obtained from organisers prior to the Competition.

*ARTICLE 11: ELECTRICAL SYSTEM (<40V) and SHUTDOWN SYSTEM - as per 2012 FSAE Rules except as follows for alternative powertrains unless mechanical throttle actuation is used*

**B11.1 Main Master Switch**

*There must be one master switch placed on the right hand side of the car in proximity of the main hoop. This switch must completely disable power to the control system and all LV systems*

**B11.2 Tractive System Master Switch**

A tractive system master switch which disables the tractive system must be fitted to allow work to be done on other systems on the vehicle. This must be placed on the right hand side of the vehicle next to the master switch. The tractive system master switch must be fitted with a "lockout/tagout" capability to prevent accidental activation of the High Voltage system. The tractive system master switch must be placed between the electrical components that make up the shutdown system and the accumulator isolation relays. The safety responsible must ensure that the system is used whenever work is done on the vehicle.

**B11.3 Shutdown Buttons and the shutdown system**

There must be a minimum of three shutdown buttons, one on each side of the car just behind the driver's compartment at approximately the level of the driver's head, and one on or near the instrument panel easily reachable by the driver. *These buttons form part of the shutdown system.*

When the shutdown system is activated the following actions must be taken:

- The flow of current holding the accumulator isolation relays closed must be broken
- the motor(s) must be controlled to target zero torque

For any hybrid or combustion engine vehicles, the following additional actions must be taken

- the engine must be turned off
- the fuel pump must be switched off
- electrical power to any drive by wire throttle must be removed and the throttle must automatically fail to the closed position

The implementation must be as shown in figure 2 or equivalent.

Once pushed, these buttons must stay in until manually pulled outward to reset the system. The two outer buttons must be red, 40 mm (2.4 inch) diameter (*Omron A22E-MP* or equivalent) the driver's shutdown button must be red, with a minimum diameter of 25.4 mm (1 inch).

**B11.4 Shutdown System Measurement Point**

A protected 4mm banana socket must be placed between the shutdown system components and the tractive system master switch so that it is possible for the scrutineers to test the functionality of the shutdown system components before allowing the isolation relays to be tested. The loop back plug location is shown in figure 2.

**B11.5 Inertia Switch**

All vehicles must be equipped with an inertia switch. This must be a Sensata Resettable Crash Sensor or equivalent if approved by the organisers. This device must be part of the shutdown system and must be wired in series with the shutdown buttons such that an impact will result in the shutdown system being activated and controlling the systems as defined in B11.3. This system must latch until manually reset. The device must trigger due to an impact load which decelerates the vehicle at between 6g and 11g depending on the duration of the deceleration (see spec sheet of the Sensata device). This may be reset by the driver in the driver's cell. The implementation must be as shown in figure 2 or equivalent. It must be possible to demount the device so that its functionality can be tested by shaking it

**B11.6 LV Batteries (<40V) used to start the engine and to provide power to LV electronics for all vehicles**

- B11.6.1 All LV batteries, i.e. on-board power supplies, must be attached securely to the frame.
- B11.6.2 Any wet-cell battery located in the driver compartment must be enclosed in a nonconductive marine-type container or equivalent.
- B11.6.3 The hot (*ungrounded*) terminal must be insulated.
- B11.6.4 The negative (*grounded*) battery lead must be clearly recognisable and if necessary it must be identifiable with yellow tape.
- B11.6.5 Except for vehicles with HV electrical systems, battery packs based on Lithium Chemistry other than LiFePo:  
a. must be commercially manufactured items  
b. must have over voltage, under voltage, short circuit and over temperature cell protection  
For vehicles containing HV electrical systems, a team built LV battery pack may be used, but details on how B11.6.5b is achieved must be included as part of the ESF submission.
- B11.6.6 All batteries using chemistries other than lead acid must be presented at technical inspection with markings identifying it for comparison to a datasheet or other documentation proving the pack and supporting electronics meet all rules requirements

**ARTICLE 12: AERODYNAMIC DEVICES - as per 2012 FSAE Rules**

**ARTICLE 13: COMPRESSED GAS SYSTEMS AND HIGH PRESSURE HYDRAULICS - for compressed gas fuels**

**B13.1 Compressed Gas Cylinders and Lines**

- B13.1.1 Any system on the vehicle that uses a compressed gas as an actuating medium must comply with the following requirements:
- Working Gas-The working gas must be non-flammable, e.g. air, nitrogen, carbon dioxide.
  - Cylinder Certification- The gas cylinder/tank must be of proprietary manufacture, designed and built for the pressure being used, certified by an accredited testing laboratory in the country of its origin, and labelled or stamped appropriately.

- c. Pressure Regulation-The pressure regulator must be mounted directly onto the gas cylinder/tank.
- d. Protection - The gas cylinder/tank and lines must be protected from rollover, collision from any direction, or from damage resulting from the failure of rotating equipment.
- e. Cylinder Location- The gas cylinder/tank and the pressure regulator must be located either rearward of the Main Roll Hoop and within the envelope defined by the Main Roll Hoop and the Frame (see B.3.2), or in a structural side-pod that meets the requirements of B.3.24 or B.3.31. It must not be located in the cockpit.
- f. Cylinder Mounting- The gas cylinder/tank must be securely mounted to the Frame, engine or transmission.
- g. Cylinder Axis- The axis of the gas cylinder/tank must not point at the driver.
- h. Insulation- The gas cylinder/tank must be insulated from any heat sources, e.g. the exhaust system.
- i. Lines and Fittings- The gas lines and fittings must be appropriate for the maximum possible operating pressure of the system.

**ARTICLE 14: FASTENERS - as per 2012 FSAE Rules**

**ARTICLE 15: TRANSPONDERS - as per 2012 FSAE Rules**

**ARTICLE 16: VEHICLE IDENTIFICATION**

**B16.1 Car Numbers as per 2012 FSAE regulations except**

- B16.1.1 Any car which uses electrical energy as a means of propulsion must use a light green background for the numbers.

**B16.3 Formula Student Hungary Logo**

Each car will be required to append a Formula Student Hungary logo, 20 cm x 10 cm, marking on the nose of the car (supplied by the organisers at event sign-on). No sponsor or other markings will be permitted to encroach on these areas.

**B16.4 Technical Inspection and Driver ID Sticker Space**

- B16.4.1 Technical inspection stickers will be placed on the upper nose of the vehicle. Cars must have a clear and unobstructed area at least 12.5 x 10cm, which will be used to record the car weight and identify the sections of scrutineering that have been completed.
- B16.4.2 Vehicles that are being entered into multiple competitions in the FSAE series must allow sufficient space along the nose centerline for all inspection stickers.

## ARTICLE 17: EQUIPMENT REQUIREMENTS - as per 2012 FSAE Rules except

### B17.2 Helmet

A well-fitting, closed face helmet that meets one of the following certifications and is labeled as such:

- Snell SA2000, SA2005, SA2010
- FIA 8860-2004
- British Standards Institution BS 6658-85 Type A/FR rating (Types A and B are not accepted)

Open faced helmets are not approved.

All helmets to be used in the competition must be presented during Technical Inspection where approved helmets will be stickered. The organizer reserves the right to impound all non-approved helmets until the end of the competition.

### B17.5 Suit

The Driver's suit must comply with FIA 8856-2000 or FIA 1986 Standard.

## ARTICLE 18: Possible Future Rules Changes - as per 2012 FSAE Rules and FSH Supps

## ARTICLE 19: HIGH VOLTAGE ELECTRICAL SYSTEMS

Note: It is strongly recommended that teams follow recognised standards and guidelines when designing and construction their vehicle. The recommended standards are contained in FSH Appendix B3 and should be complied with wherever possible. Disregarding these engineering and construction practices can cost a team design points. Where there are differences between these guidelines and the Formula Student Hungary rules, the Formula Student Hungary rules will take precedence.

### B19.1 Definition of High voltage system

High Voltage is defined as any system (individually or in series) containing or producing a voltage greater than 40V DC or 25V AC relative to any other electrical system on the car. Any part of the HV system that is electrically connected to the electric motor(s) can be referred to as the tractive system.

Note: All Teams using HV systems must include details of this in their *electrical safety form* (B21)

### B19.2 High-Voltage (HV) Isolation

There must be no connection between the frame of the vehicle (or any other conductive surface that might be inadvertently touched by a crew member or spectator), and any part of any HV circuits. *Except for interlock circuit connections*, HV and low-voltage circuits must be physically segregated such that they are not run through the same conduit.

LV must not be included in the accumulator container except for required purposes, for example the AMS. Wherever possible any LV wiring within the accumulator enclosure must be galvanically isolated from the rest of the LV system. This must be demonstrated in the ESF submission.

Where both are present within an enclosure, they must be separated by insulating barriers made of moisture resistant, UL recognized insulating materials rated for 150 C or higher (eg Nomex based electrical insulation), or maintain the following spacings through air, or over a surface (similar to those defined in UL1741):

- $V < 100V$  1 cm (0.4 inch)
- $100 < V < 200V$  2 cm (0.75 inch)
- $V > 200V$  3 cm (1.2 inch)

Spacing must be clearly defined. Components and cables capable of movement must be positively restrained to maintain spacings.

If both are on the same circuit board, they must be on separate, clearly defined areas of the board. Required spacing are as follows:

Voltage	Over Surface	Thru Air (Cut in board)	Under Coating
<b>0-50</b>	1.6 mm (1/16")	1.6 mm (1/16")	1 mm
<b>50-150</b>	6.4 mm (1/4")	3.2 mm (1/8")	2 mm
<b>150-300</b>	9.5 mm (3/8")	6.4 mm (1/4")	3 mm
<b>300-600</b>	12.7 mm (1/2")	9.5 mm (3/8")	4 mm

Teams must be prepared to demonstrate spacings on team-built equipment. Information on this must be included in the electrical safety form (B21). For inaccessible circuitry, spare boards or appropriate photographs must be available for inspection.

**B19.3 Insulation Monitoring Device (IMD)**

B19.3.1 All vehicles must be equipped with an on-board *IMD* which must be integrated into the shutdown system. This must be a *Bender IR155-1, IR155-2* or equivalent if approved by the organisers. The output relay of this device must be wired in series with the shutdown buttons such that an insulation fault will activate the shutdown system which results in the actions as defined in B11.3 and latches off until manually reset from outside of the car. The *IMD* must have a remote LED indicator clearly marked with "*IMD*" in the driver's cell to show when it has tripped. An *IMD* reset button may not be accessible from the driver's position. The implementation must be as shown in figure 2 or equivalent.

B19.3.2 The *IMD* must be set to trip when the insulation resistance is below 500 Ohms / Volt. The voltage to be used must be the maximum tractive system operation voltage.

B19.3.3 The *IMD* Test will be performed during technical inspection, by connecting, a resistor set at 250 Ohms/Volt between multiple points on the HV circuit and the grounded frame with the HV systems at full charge (See Figure 1). This must cause the *IMD* to trip within 30 seconds, and the vehicle electrical systems to shut down within a further 5 seconds.

B19.3.4 This test may be repeated by the electrical inspectors at any time during the competition.

B19.3.5 Once the *IMD* test has been satisfactorily completed, the scrutineers will seal the High Voltage enclosures. If the seals are broken, the vehicle may not participate in any dynamic events until the *IMD* test has been satisfactorily repeated. (If a repair is simple, and done in the presence of an Electrical Inspector, the Chief Electrical Inspector may choose to waive the re-testing requirement.)

**B19.4** **Insulation Measurement Test (IMT)**

*The insulation resistance between the tractive system and control system ground will be measured during scrutineering. The available measurement voltages are 250V and 500 V. All cars with a maximum nominal operation voltage below 500V will be measured with the next available voltage level e.g. a 175V system will be measured with 250V, a 300V system will be measured with 500V etc. All teams with a system voltage of 500 V or more will be measured with 500V. To pass the IMT the measured insulation resistance has to be at least 500 Ohm/Volt related to the maximum nominal tractive system operation voltage.*

**B19.5** **Rain Certification**

B19.5.1 All vehicles running HV systems must be rain certified

B19.5.2. To become Rain Certified, a vehicle must first pass the IMD test outlined in B19.3.2. It must then survive a 120 second water spray with all systems energized *and must then stand for a further 120 seconds* without tripping the IMD. The water spray will be directed from the top, front and sides of the vehicle. The spray is intended to simulate rain and will typically have drops ranging in size between 0.1 to 5 mm in diameter. A strong stream of water will not be directed at the vehicle.

B19.5.3 Once a vehicle has been rain certified, the bodywork cannot be modified unless the vehicle is re-certified.

**B19.6** **No Exposed HV Connections**

B19.6.1 There must be no exposed HV connections. There must be no exposed HV connections. In order to achieve this, it must not be possible to touch any HV connections with a 10 cm long, 0.6 cm diameter (4 x 1/4 inch) insulated test probe when the HV enclosures are in place.

B19.6.2 Non-conductive covers must prevent inadvertent human contact with any HV. This must include crew members working on or inside the vehicle. Covers must be secure and adequately rigid. Body panels that must be removed to access other components, etc. are not a substitute for enclosing HV connections.

B19.6.3 HV systems and containers must be protected from moisture in the form of rain or puddles for any car that is certified to run rain or wet conditions. Note: A rating of IP65 is recommended

B19.6.4 There will be no HV connections behind the instrument panel or any driver's cell switch or control panels.

B19.6.5 All controls, indicators and data acquisition connections must be isolated using optical isolation, transformers or the equivalent.

B19.6.6 Any components (eg. Electronic throttle or regenerative controls) carrying high voltage must be mounted outside the driver's cell area unless *separated from the driver by a firewall*.

**B19.7** **HV Insulation, Wiring and Conduit**

B19.7.1 All insulation materials used in HV systems must be rated for the maximum temperatures expected.

B19.7.2 Insulated wires must be commercially marked with a wire gauge, temperature rating and insulation voltage rating. Where short sections of cable are used, it is allowable to provide to the scrutineers a section of equivalent cable which contains these markings. Other insulation materials

must be documented. The minimum acceptable temperature rating for HV cables is 90°C. If the cable incorporates a shield then this shield must be grounded.

- B19.7.3 All HV wiring must be done to professional standards with appropriately sized conductors and terminals and with adequate strain relief and protection from loosening due to vibration etc.
- B19.7.4 All HV wiring that runs outside of electrical enclosures must be enclosed in *separate* orange non-conductive conduit, such as Electri-flex LNMP or equivalent. The conduit must be securely anchored at least at each end, so that it can withstand a force of 200N without straining the cable and must be located out of the way of possible snagging or damage.
- D 3.7.5 All HV connections must be designed so that they use intentional current paths through conductors such as copper or aluminium and should not rely on steel bolts to be the primary conductor. The connections must not include compressible material such as plastic in the stack-up.

### **B19.8 Fusing**

All electrical systems (both low and high voltage) must be appropriately fused. Any wiring protected by a fuse must be adequately sized and rated for current equal to the fuse rating (See wire requirements in B19.7)

The continuous current rating of a fuse must not be greater than the continuous current rating of any electrical component, for example wire, busbar, cell or other conductor that it protects. All fuses and fuse holders must be rated for the highest voltage in the systems they protect. Fuses used for dc must be rated for dc, and must carry a dc rating equal to or greater than the system voltage FSH Appendix B1.

Any fuse must have an interrupt current rating which is higher than the theoretical short circuit current of the HV system that it protects.

If multiple parallel strings of batteries or capacitors are used then each string must be individually fused. If individual fuses are used this will provide a total fusing equal to the number of fuses multiplied by the fuses rating. Any conductors, for example wires, busbars, cells etc conducting the entire pack current must be appropriately sized to this total fusing or an additional fuse used to protect the conductors.

Note: If more than one cell or capacitor is used to form a set of single cells in parallel such that groups of parallel cells are then combined in series, then either each cell must be appropriately fused or the cell manufacturer must certify that it is acceptable to use this number of single cells in parallel.

Any certification must be included in the ESF

Multiple parallel fuses in a single string are not permitted.

Starter Motor wiring (Battery/Relay/Motor) is not required to be fused.

### ***B19.9 HV Loop Back Plug***

A loop back plug which is coloured red or has a handle coloured red must be included in the HV circuit such that the loop back plug can be removed to manually disconnect the HV. The loop back plug must be accessible from the outside of the vehicle and placed on top or to the rear of the accumulator with no obstructions including HV cables. It must be possible to remove the loop back plug within 10 seconds.

**B19.10 Accumulator Type and Size**

B19.10.1 Total accumulator voltage may not exceed 600V. This will be checked before the start of the endurance event.

B19.10.2 Accumulator capacity *must* not exceed 7,250 Wh as specified in B19.10.4.

B19.10.3 Teams must state, as accurately as possible, their accumulator capacity. Energy accumulators must be of an approved type. Batteries and capacitors are approved accumulators. A team must gain approval for any other types of accumulator.

B19.10.4 The following equations must be used to determine accumulator size Where C, Vnom, Vpeak and Ah are device nameplate values:

Batteries:

$$Energy(Wh) = (Vnom)(Ah)(0.8)$$

Capacitors

$$Energy(Wh) = \left( \frac{C(V_{peak}^2 - V_{min}^2)}{2} \right) / 3600$$

where *Vmin* is assumed to be 10% of *Vpeak*.

**B19.11 Accumulator Monitoring**

B19.11.1 An accumulator monitoring system appropriate for the accumulator type is required. The accumulator monitoring system (AMS) must monitor the accumulator to prevent overcharging and hazardous thermal conditions. The functions of the AMS must be described in the Electrical Safety Form (B21)

The table below lists the required functions for the AMS based on accumulator type.

Accumulator Type	Temperature Monitoring	Voltage Monitoring
Lead Acid Battery	Per module	
NiMh Battery	Per module	Per module
Lilon Battery	<i>30% of cells</i>	Per cell
Ultra Capacitor	Per module	

Other battery types require approval of the Accumulator Monitoring System as part of the electrical safety form process. Note, a battery module is considered to be a group of up to 12 battery cells. If you anticipate having more than 12 cells in a module then this must be clearly highlighted in the electrical safety form with suitable justification.

*Note: it is allowable to use one temperature sensor attached to 2 cells.*

All voltage sense wires to the AMS must be either protected by fuses as defined in D3.8, or must be protected by resistors so that they cannot exceed their current carrying capacity in the event of a short circuit. Any fuse or resistor must be located at the connection to the HV component.

Any LV connections to the AMS must be galvanically isolated, including any connections to external devices such as laptops.

- B19.11.2 Active balancing is a mechanism to equalize state of charge or cell voltage in strings of series cells and is recommended for Lilon batteries.
- B19.11.3 The accumulator monitoring system must control a relay wired in series with the shutdown buttons such that an insulation fault will activate the shutdown system if a hazardous condition (e.g. over-voltage, undervoltage, cell reversal, over-temperature) is detected. The actions of the shutdown system are covered by B11.3. The system must remain disabled until manually reset. An AMS reset button must not be accessible from the driver's position. An indication light must be provided in the driver's cell which is clearly marked "AMS" so that an AMS fault can be recognised by the driver.

Bimetallic thermal switches are acceptable means of providing over-temperature protection.

- B19.12 Energy Storage Container Electrical Configuration
- B19.12.1 All energy storage must be in closed containers containing normally open isolation relays on both positive and negative sides of the storage device wired in such a way that when an incoming energize signal is interrupted there is no HV connection to the outside of the containers.
- B19.12.2 Each Energy Storage Container must also include an appropriately rated fuse or circuit breaker.
- B19.12.3 The relays must be rated to interrupt the rated fuse current at the maximum expected voltage.
- B19.12.4 Contactors and relays containing mercury are not permitted.
- B19.12.5 The stored energy in any energy storage container must be divided into stacks where the following requirements must be met:*
- *each stack must have a maximum voltage of 120V at any time*
  - *each stack must not exceed 5MJ of stored energy when fully charged*
  - *It must be possible to isolate each stack by the use of maintenance plugs such that no sections of the HV system exceeds the above voltage and energy storage limits*
- Note: It is expected that as soon as the energy storage container is opened and especially before any stack is removed from the energy storage container the maintenance plugs will be disconnected.*
- B 19.12.6 Connecting the cells in the battery pack by soldering in the high current path is prohibited. Note: Soldering wires to cells for the voltage monitoring input of the AMS is allowed, since these wires are not part of the high current path.*
- B19.12.7 Multiple energy storage containers connected in parallel or series may be used however the following requirements must be met:
- a. There must be a contactor at both the positive and negative terminal of each energy storage container such that no voltage is present outside of any energy storage container once the contactors are deenergised.
  - b. HV electrical connections between the containers must be protected by non-conductive conduit (See Section B19.7) anchored solidly to the containers.
  - c. The cables must be contained within the primary structure of the chassis.

- B 19.12.8 Pre-charge and discharge circuits must be designed as follows:*
- a. A circuit that is able to pre-charge the intermediate circuit to at least 90% of the current accumulator voltage before closing the second accumulator contactors must be implemented. It must be possible to deactivate this system by the safety circuit, article B11.3. Therefore the pre-charge circuit must not be able to pre-charge the system, if the safety circuit is open.*
  - b. It is allowed to pre-charge the intermediate circuit for a conservatively calculated time, before closing the second accumulator contactor. A feedback via measuring the current intermediate circuit voltage is not required.*
  - c. If a discharge circuit is needed to achieve 40VDC in 5 seconds then this must be designed to handle the maximum discharge current for at least 15 seconds. The calculation proving this has to be part of the ESF. Any resistor in the system must also be rated for the full system voltage.*
  - d. The discharge circuit must be wired in a way that it is always active whenever the safety circuit is open. Furthermore the discharge circuit has to be fail-safe.*
- B19.12.9** The power supply for the HV accumulator relays must only be active when the *shutdown system and driver controls and ECU* are set to enable them to be activated. Where the motor controller(s) require a LV power supply this must also be active before the accumulator relays can be powered. *The power supply to the accumulator relays must be configured so that it can be interrupted by any of the following devices:*
- *the brake over-travel switch (B7.3)*
  - *the tractive system master switch (B11.2)*
  - *3 shutdown buttons (B11.3)*
  - *the inertia switch (B11.5)*
  - *the IMD (B19.3)*
  - *the AMS (B19.11.3)*
  - *the required interlocks on any of the HV cable connections between the HV accumulator and motor controller(s) (B19.12.9)*
  - *any interlocks for outboard wheel motors (B19.13.2)*
  - *the relay power controller (B20.4).*
- B19.12.10** It must only be possible to close the accumulator relays once the HV cables are connected correctly between the accumulator and the motor controller. If the cable is not connected to the motor controller, or a connector on the cable is not connected then an interlock in the power supply to the accumulator relays must be broken. *The interlocks must be wired in series with the shutdown system such that when any interlock is disconnected, the shutdown system is activated.* The implementation must be as shown in figure 2 or equivalent.
- B19.12.11 Two tractive system voltage measuring points must be installed directly next to the master switches. The measuring points must meet the following requirements:*
- *they must be protected by a non-conductive housing that can be opened without tools.*
  - *They must be protected from being touched with the bare hand / fingers, once the housing is opened.*
  - *4mm banana jacks rated to an appropriate voltage level have to be used*
  - *The measuring points must be connected to the positive and negative motor controller/inverter supply lines.*
  - *Any test leads used with the measuring points must be appropriately rated*

*Note: These measuring points will be used to check during E- Scrutineering to prove that the tractive system is shut down properly in the given time. They are also needed to ensure the safety of the vehicle for possible rescue operations after an accident or when work on the vehicle is to be done.*

- B19.12.12 Each energy storage container must have a prominent indicator to warn of HV.

Each energy storage container must have a prominent indicator, such as an LED that will illuminate whenever there is greater than 40V DC at the outer connector. This must be achieved by driving the LED using analogue circuitry directly from the accumulator output. This must be clearly visible in direct sunlight. As an alternative, the accumulator container may contain an “embedded” analogue meter clearly visible from the outside. This device must also work when the energy accumulator is removed from the vehicle.

Each energy storage container must have a label at least 200 cm<sup>2</sup> with the text “High Voltage ALWAYS ENERGIZED”

**B19.13 Energy Storage Container Mechanical Configuration**

- B19.13.1 The energy storage container and mounting system must be sturdy, considering forces encountered during on-course competition and the possibility of a rollover accident. The mounting system must be designed to withstand forces from a 20g deceleration such that the HV system does not enter the driver’s cell area and 10g deceleration in any other direction. Proof of meeting this requirement must be shown in the SES.

The materials used to construct the container should be electrically insulating, mechanically robust, and ideally transparent to allow easy inspection. Not all of these properties are available in a single material, but the following are required:

- At least one layer of fireproof material *in the line of sight* between the driver and the energy storage container *which is rated to a flammability standard of at least UL94-V0.*
- Mechanically robust, fireproof insulating material (e.g., Nomex) between live electrical parts and any conductive portions of the container.
- Adequate structural robustness for the weight of the accumulator.

- B19.13.2 *If the energy storage container is made from conductive material then the energy storage components (eg. battery cells) must be electrically isolated from the container using an isolative material which is which is rated to a flammability standard of at least UL94-V0.*

- B19.13.3 *Within the energy storage containers, each energy storage stack (B19.12.5) must be isolated from the other energy storage stacks by using an isolative material which is which is rated to a flammability standard of at least UL94-V0.*

*Note: For intrinsically safe cells, this barrier can be electrically isolating, but the flammability standard is not required. Agreement to use a non- fireproof barrier must be sought from the organisers.*

- B19.13.4 Any energy storage container, HV system wiring and HV system components must be contained within the frame and if positioned below 350mm from the ground must be protected from impact by another vehicle by structure meeting FSAE rule B3.24 or B3.31.

Outboard wheel motors are allowed where the motor is outside of the frame but only if an interlock is added such that the HV system is de-activated if the wheel assembly is damaged or knocked off the car. Any interlock solutions must be covered by the ESF.

- B19.13.5 There must be no unintentional electrical conduction paths through any of the walls of the container. (Metal screws, rivets, etc.)
- B19.13.6 The container must be prominently labelled with high voltage signs, at least 200 cm<sup>2</sup>, with a red (or white on red) lightning bolt. Containers which hold Batteries must be labelled with the text as defined in B19.11.11. Containers which hold capacitors must be labelled with the text —High Voltage or — Danger High Voltage.
- B19.13.7 Systems capable of venting H<sub>2</sub> gas (batteries) must have an active ventilation system that is active whenever the system is charging, whether from on-board or off-board sources.

#### **B19.14 Grounding**

- B19.14.1 All electrically conductive parts of the vehicle (e.g. parts made of steel, (anodized) aluminium, any other metal parts) which could contact a damaged wire or electrical part, no matter if HV or LV, must have a resistance below 300 mOhm (measured with a current of 1A) to control system ground.*
- B19.14.2 Attachment point of any monocoque chassis (eg driver harness, roll hoop or suspension attachment point must have a resistance below 300 mOhm (measured with a current of 1A) to control system ground.*
- B19.14.3 All parts of the vehicle which may become electrically conductive (e.g. completely coated metal parts, carbon fibre parts) which could contact a damaged wire or electrical part, no matter if HV or LV, must have a resistance below 5 Ohm (measured with a multimeter) to control system ground. This may be tested by checking any points which are likely to be conductive, for example the driver's harness attachment bolt, but where no convenient conductive point is available then an area of coating may be removed. Note: Particular attention will be made to driver controls.*

#### **B19.15 Low-Voltage Circuits**

- B19.15.1 Low-voltage (< 40 V) circuits must be grounded to the frame of the car. (This ensures that, in the event of a fault in the isolation of the HV circuit, no HV will be present between controls or anything else that personnel might touch and the frame.) If the low-voltage circuits are powered by a battery or other source that is not inherently current limited, proper fusing must be used.
- B19.15.2 Any wire used in the grounding system must have at least the current carrying capacity of the LV circuit that it protects
- B19.15.3 Low-voltage and HV circuits *except for interlock circuit connections* must be segregated and isolated as described in Section B19.2
- B19.15.4 The capacity of the Low Voltage battery need not be included in the overall vehicle accumulator capacity calculations.

#### **B19.16 Charging Equipment**

- B19.16.1 All charging equipment must be maintained in safe working condition.
- B19.16.2 High Voltage chargers and/or power supplies must be marked with appropriate High Voltage stickers.

- B19.16.3 If any voltage remains outside the charger after the power is turned off then any open connections must be securely covered.
- B19.16.4 All chargers must be UL (Underwriters Laboratories) or CE listed. The vehicle must be de-energized while charging from external sources (as much as possible while still allowing charging), and no other activities (including any mechanical or electrical work) shall be allowed.
- B19.16.5 When the on board accumulator is recharging with an off board charger, the chassis of the vehicle and the external charger must share a common earth. This Earth connection must be made before the energy storage unit is allowed to recharge.

**B19.17 *Tractive-system-active light (TSAL)***

*The TSAL must be clearly visible when the tractive system is set to active. The car is defined as active whenever the accumulator insulation relay is closed or the voltage outside the accumulator containers exceeds 40V DC or 25V AC RMS. For this the car must be equipped with a light mounted under the highest point of the main roll hoop which lights if the car's tractive system is active and which is off when the tractive system is not active, see definition above. The following TSAL requirements must be respected:*

- a. The TSAL must be red.*
- b. The TSAL has to flash continuously with a frequency between 2Hz and 5Hz.*
- c. The voltage must directly control the TSAL using hard wired electronics (no software control is permitted)*
- d. The TSAL has to be clearly visible from every horizontal direction, except small angles which are covered by the main roll hoop, even in very bright sunlight.*
- e. It must not be possible for the driver's helmet to contact the TSAL*

*NOTE: If any official e.g. track marshal, scrutineer, etc. considers the TSAL to not be easily visible during track operations the team may not be allowed to compete in any dynamic event before the problem is solved. It is prohibited to mount other lights in proximity to the TSAL.*

**B19.18 *Ready to Drive Sound***

*The car has to make a characteristic sound, once not continuous, when it is ready to drive. The car is ready to drive as soon as the motor(s) will respond to the input of the torque encoder / acceleration pedal. The sound level has to be a minimum of 70dBA, fast weighing, for between 1 and 3 seconds in a radius of 2m around the car. The used sound has to be easily recognizable. No animal voices, song parts or sounds that can be interpreted as offensive will be accepted.*

**ARTICLE 20: VEHICLE CONTROL SYSTEMS**

- B20.1 *Drive by Wire systems*** - Drive-by-wire systems which control the power delivered to the wheels electronically will be allowed for *alternative powertrains*. The functioning of such systems must be covered by *electrical safety form* (B21)  
Note: Front wheel steer-by-wire systems will not be allowed as per rule B3.2.4.

**B20.2 *Activating the tractive system***

In order for the car to be driven under its own power, the following actions must be taken:

1. all shutdown buttons and master switches must be correctly set
2. the driver must then activate a tractive system switch to close the contactors

3. the driver must then activate an 'ignition' switch which will enable the motor controller to deliver power to the motors power in response to the throttle pedal

**B20.3 Two independent systems to shut off power**

B20.3.1 There must be at least two completely independent systems to shut off power due to the throttle pedal being released or the brake pedal pushed. (This is the equivalent of the current two throttle return springs rule as described in the FSAE rules). The functioning of these systems must be covered by the *electrical safety form* (B21).

B20.3.2 The two systems must not share any components (such as sensors, actuators or electronic control boxes).

B20.3.3 The two systems must be independently demonstrated to the scrutineers before the car will be allowed to run (the Entrant must determine a method to perform this test such that this can be checked quickly).

B20.3.4 Any sensors included in these systems must have separate power and ground wiring.

B20.3.5 Where these systems rely on electrical sensors, these systems must be able to detect open circuit and short circuit faults on any signal wires or sensors such that any fault condition results in all power being turned off.

*B20.3.6 If two sensors, eg throttle pedal sensors, do not agree with each other within 10% then the system must shutdown. Alternatively if three sensors are used, then the if at least two sensors are within 10% of each other then the vehicle can continue*

B20.3.7 The above regulations are in addition to the brake over travel switch.

**B20.4 Actuator / Relay Power Controller / Datalogger**

B.20.4.1 An energy meter which includes a logging system for the electrical power that is used will be made available to teams at minimum cost. It is expected that this will include a simple controller which will monitor control signals for faults and provide, however it is possible that teams will be required to fulfil these requirements. Details any device or whether teams have to provide this will be displayed on the Formula Student Hungary website. The implementation must be as shown in figure 2 or equivalent.

Note: this device in no way diminishes the team's responsibility to ensure that their own control systems function correctly and safely.

B20.4.2 Power to the drive by wire throttle controller, the HV contactor relays or any other drive by wire device must pass through a simple electronic controller.

B20.4.3 The controller will monitor the control sensors and *may* remove power to the drive by wire device in the event of a sensor failure.

B20.4.4 The controller sensors will be considered to have failed when they achieve an open circuit or short circuit condition which generates a signal outside of the normal operating range (typically < 0.5V or > 4.5V)

*B20.4.5 This device will log HV electrical current and voltage. All tractive system electrical energy must pass through a single point at which the device is connected to measure the current and there can be no significant capacitance in the system downstream (on the motor side) of the measurement point.*

- B20.4.6 The datalogger system must be turned on whenever the vehicle is energised
- B20.5 Maximum Electrical Power**
- B20.5.1 The maximum electrical power measured at the HV DC cables must not exceed *85kW* at any time.
- B20.5.2 The power limit will have been deemed to have been exceeded if it has been exceeded continuously for 100ms or on average for 500ms.*
- B20.5.2 If the maximum electrical power is exceeded in any event then that event will be forfeit.*

**ARTICLE 21: REQUIREMENTS OF THE (ELECTRICAL SAFETY) FORM and FMEA**

- B21.1 Submission of (Electrical) Safety Form and FMEA** - All alternative powertrain vehicles must submit a safety form for the car covering all elements of technology that fall outside the normal FSAE regulations.  
*For electric vehicles this is referred to as the electrical safety form. The Entrant will be required to submit an FMEA for the car covering all elements of technology that fall outside the normal FSAE regulations. These documents must be signed by the safety adviser and safety responsible. Templates will be provided on the Formula Student Hungary website.*
- B21.2 Unusual aspects of design** - It is the responsibility of all entrants to discuss unusual aspects of the vehicle's design with the rules committee well in advance of the event to ensure that there are no significant problems at scrutineering.
- B21.3 (Electrical) Safety Form content** - Where appropriate, the following items must be included in the ESF
- a. Information on any changes to materials used (e.g. sealing devices) because alternate fuels are to be used.
  - b. Information on any system used which is allowed for alternative powertrains but not under FSAE rules (e.g. any system between the driver and supply or absorption of energy at the wheels, drive/brake by wire, etc.)
  - c. FMEA study to be conducted on any drive/brake by wire systems to ensure where practical all failure scenarios have been evaluated and accounted for
  - d. Where software is used this should be verified to comply with ISO 26262 Guidelines published by MIRA [<http://www.misra.org.uk/>] or similar approved guidelines must be followed
  - e. Strategy and detail of short circuit protection and specific cooling systems (e.g. for electric batteries).
  - f. Appropriate emergency equipment (e.g. fire extinguishers)
  - g. Storage & Transportation of fuels.
  - h. Means of discharge of remaining fuel (included stored electricity for capacitors)
  - i. Procedures for working on systems outside of FSAE rules (e.g. HV electrical systems, hydrogen, etc) where appropriate
  - j. Training to be conducted with students for working on systems outside of FSAE rules (e.g. HV systems, etc) where appropriate.
  - k. An outline of the overall vehicle design covering in particular the powertrain systems that are being used.
  - l. Teams will be required to have a schematic of the high voltage system which clearly indicates the wire size/rating, fuse rating, enclosures, *the LV wiring that controls the HV system (shutdown buttons etc)* and the location of any isolation between the HV and LV systems of the car.

- m. m. A detailed electrical schematic of the internal circuit of a major component in the HV system (e.g., a motor controller) is required if the circuit is designed by a team but is not required for purchased components.
- n. n. An FMEA of the AMS (Accumulator monitoring system) which manages the HV electrical system and details of the conditions under which the HV accumulator will be shut down.

**B21.4 (Electrical) Safety Form content**

Where an ESF is required, the ESF must be submitted no later than the date indicated on the competition website. Teams that submit their ESF after the due date for the competition will be penalized 10 points per day up to a maximum of 50 points, which will be taken off the team's Total Score.

**ARTICLE 22: Additional Safety Requirements**

**B22.1 Accumulator Container Hand Cart**

In case removable accumulator containers are used in order to accommodate charging, a hand cart to transport the accumulators has to be presented at Scrutineering with the following requirements met:

- The brake of the hand cart must be designed such that it can only be released using a dead man's switch, i.e. the brake is always on except when someone releases it by pushing a handle for example.
- The brake must be capable to stop the fully loaded accumulator container hand cart.
- The hand cart must be able to carry the load of the accumulator container(s).
- The hand cart(s) must be used whenever the accumulator container(s) are transported on the event site.

**B22.2 Safety Equipment**

A full list of required safety equipment is defined in FSH Appendix B2.

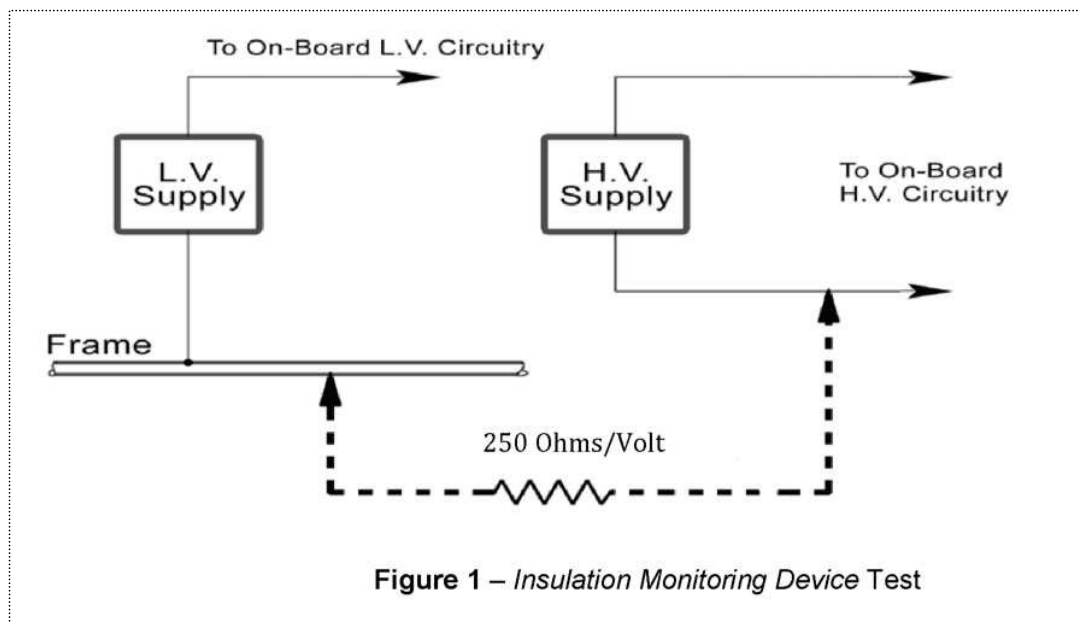

Figure 1 – Insulation Monitoring Device Test

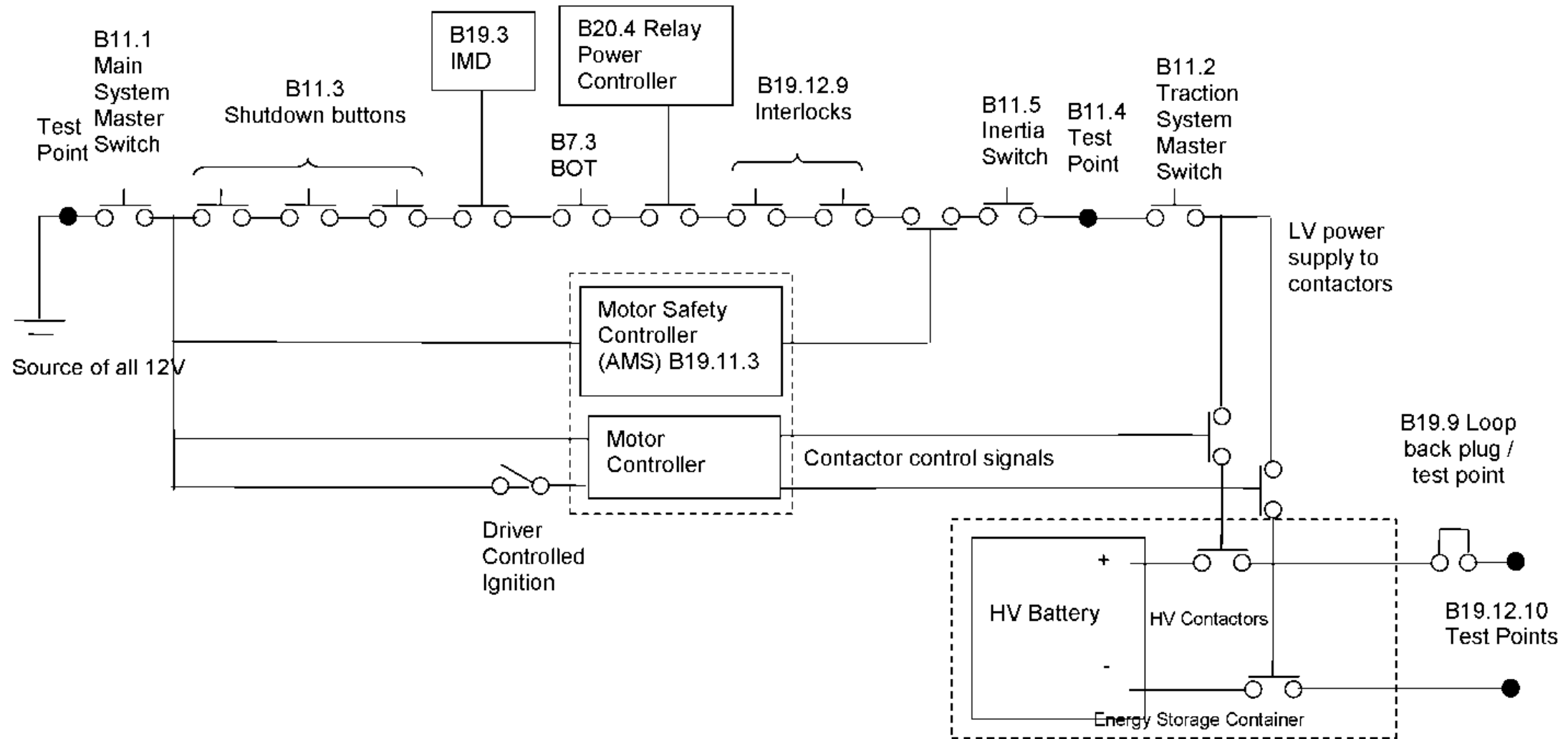

Figure 2: Typical wiring diagram of the LV electrical system <40V that controls the HV contactors or other safety critical systems (eg drive by wire throttle). This shows the intent of the wiring configuration defined by rules B7.3, B11, B19.3, B19.12.9, B19.9, etc. Whilst the exact order of some of the safety switches can be changed and there will be changes required for hybrid vehicles and vehicles with drive by wire throttles etc, the functionality of the electrical system must be equivalent to that depicted above such that any of the required switches or controllers must be able to directly turn off the safety critical systems (eg HV contactor relays).

### FSH Appendix B1 - Wire Current Capacity (DC)

Wire AN gauge Copper	Wire Area (Thousands of circular Mils)	Max. Fuse Continuous Rating
24		5
<b>22</b>		7
20		10
18		14
16		20
14		28
12		40
10		55
8		80
6		105
4		140
3		165
<b>2</b>		190
1		220
0		260
2/0		300
3/0		350
4/0		405
	250	455
	300	505

## FSH Appendix B2 - Required Equipment for Vehicles with HV Electrics

### Fire Extinguishers

#### Minimum Requirements

Each team must have at least two (2) 2.3 kg (5 lb.) dry chemical (Min. 3-A:40-B:C) Fire extinguishers

Extinguishers of larger capacity (higher numerical ratings) are acceptable.

All extinguishers must be equipped with a manufacturer installed pressure/charge gauge.

#### Special Requirements

Teams must identify any fire hazards specific to their vehicle's components and if fire extinguisher/fire extinguisher material other than those required in section 3.4.11.2 (A) are needed to suppress such fires, then at least two (2) additional extinguishers/material (at least 5 lb or equivalent) of the required type must be procured and accompany the car at all times.

#### Chemical Spill Absorbent

Teams must have chemical spill absorbent at hand, appropriate to their specific risks. This material must be presented at technical inspection.

#### Cable Cutters

Insulated cable cutters. These must be capable of cutting live HV cables in the event of a serious malfunction. Following is the list of approved cable cutters.

- Bahco 2520s
- Knipex 95 17 500
- Knipex 95 27 600
- Willi Hahn Corp (Wiha) 119 50
- Willi Hahn Corp (Wiha) 408 00

Any other cutters must be approved by the organisers in advance.

#### Insulated Gloves

Insulated gloves, rated for at least the voltage in the HV system, with protective overgloves.

#### Safety Glasses

Safety glasses must be worn as specified in section 0

#### MSdS Sheets

Materials Safety Data Sheets (MSDS) for the accumulator.

#### Additional

Any special safety equipment called for in the MSDS, for example correct gloves recommended for handling any electrolyte material in the accumulator.

## **FSH Appendix B3 - Recommended Standards**

- SAE Standard J1673 - “High Voltage Automotive Assembly Wiring Design”
  - ISO\_6469-part 1 : Electric road vehicles — Safety specifications: On board electrical storage
  - ISO\_6469-part 2 : Electric road vehicles — Functional safety means and protection against failures
  - ISO\_6469-part 3 : Electric road vehicles — Safety specifications: Protection of persons against electric hazards
  - SAE J2344 : Guidelines for electric vehicle safety
- IEC 61508: Functional safety of electrical/electronic/programmable electronic safety related systems (FOTA were proposing this for future F1 KERS)

## 2012 Formula Student Hungary Rules

### PART C - STATIC EVENT REGULATIONS

#### ARTICLE 1: STATIC EVENTS, MAXIMUM SCORES AND BUSINESS LOGIC CASE

##### C1.1 Maximum Score

The maximum possible scores in the static events are:

Business Logic Case	No	Points
Technical Inspection	No	Points
Sustainability	100	Points
Business Presentation	75	Points
Design	150	Points
<b>Total</b>	<b>325</b>	<b>Points</b>

##### C1.2 Business Logic Case

Overall, the business logic case is designed to integrate all aspects of the static events whilst encouraging teams to consider the competing aspects of design, cost and marketing early in the project

##### C1.2.1 Objective of the Business Logic Case

The Objectives of the Business Logic Case are:

- To teach participants about the factors that need to be considered when a company embarks on a new product development which includes, cost, identification of market, profitability and the key design features desired
- To ensure teams develop the concept of their entry with all of these aspects correctly considered, from the outset
- To ensure that all static events are approached with a single common concept which will be presented to each set of static judges in the same manner
- To fast track the learning of participants in gaining experience of producing a business case.

##### C1.2.2 How the Business Logic Case will be used

- The Design, Cost and Business Presentation judges will use the business logic case to see if the information presented at each static event are consistent with the overall project objectives as outlined in the Rules
- In the Design event, the business logic case will be used to see how you determined the trade off between design for performance and design for manufacture and cost, and how these requirements were considered in your concept and whether this is achieved in the realisation of your project
- In the Cost event, the business logic case will be used to determine whether your cost target was met for the same design solution
- In the Business Presentation event, the business logic case will be used to assess whether your business presentation is appropriate for the market and business strategy that you identified
- For Formula Student, Hungary if the event is over subscribed, then the entry selection process may include assessment of the quality of the Business Logic Case you supplied.

C1.2.3 All teams are required to submit a Business Logic Case report which explains the rationale behind the vehicle design that they propose to produce and enter.

C1.2.4 This report must be submitted ~ 3 months before the competition. Please see the deadlines posted on the website.

- C1.2.5 The report must be submitted to the FSH database on a 2 page template which must be accompanied with the conceptual Design Spec Sheet. Please see the website to acquire the templates.
- C1.2.6 There are no specific points assigned to this task, however the proposals presented may have an influence on your entry acceptance, and your Design, Cost and Business Presentation scores. Specifically, and for the avoidance of doubt, this submission is mandatory and is designed to remove the possibility that Design, Cost and Business Presentation judges may be offered three quite different “design concepts”. A common concept is required.
- C1.3 Late Submission of the Business Logic Case  
Teams that submit reports late will be penalized 10 points per day late, with a maximum penalty of negative 50 points. Teams that do not submit a Business Logic Case are unlikely to gain an entry to the competition. Penalties will be applied based on official upload date and time for electronic submission and by post mark for printed submissions.

**ARTICLE 2: TECHNICAL INSPECTION - as per 2011 FSAE Rules except the following will apply to the impact attenuator**

The Impact Attenuator (IA) report will be assessed and moderated before the event. Reports that are considered to be poor will incur a penalty of up to 10 points which will be applied to the Design score. The report must use the form in FSAE rules Appendix B-2.

Once graded, the grade will be converted into a Design event penalty using the following scaling:

- A no penalty
- B no penalty
- C -1 point
- D -5 points
- E -8 points
- F -10 points

If a report scores an F then the IA design will also be judged to be a Fail and therefore the car will not be issued with a scrutineering sticker until the report and associated data is improved to achieve a Pass. Any reports that are late will receive an automatic F and the associated penalty, however if the report contents are adequate then a Pass will be issued. In the event that a report or design is poor and initially graded F then the -10 point penalty will remain even after improvements have been submitted.

Teams that choose to use the ‘standard impact attenuator design’ B.21.11 with no data in their IA report will be automatically graded E. Those teams that use the Standard IA can have their score upgraded to a maximum of a C grade which could be achieved by writing a good report containing calculations and for example some crush testing of the material.

The basic concept of the grading is that the report will be given a “base grade” based on the type of testing the team performed. This “base grade” will be then adjusted depending on whether certain other criteria are met and upon the quality of the report itself.

There are four steps in grading the reports:

1. Was the report submitted on time (FSAE Rules A8.4)?
2. Was the report submitted in the correct format and containing the required information?
  - i. That the report be in Adobe Acrobat (B.3.21.5) and be named a specific way. (B.3.21.6)
  - ii. That it contain test data. (B.3.21.1)
  - iii. That the test data show that the average deceleration is no more than 20 g's. (B.3.21.1)
  - iv. That the maximum deceleration is no more than 40 g's. (B.3.21.1)
  - v. That a schematic of the test method be included. (B.3.21.3)
  - vi. That photographs of the attenuator before and after the test be included. (B.3.21.3)
3. What method of testing was used and does the test data support the claimed conclusions, e.g. the deceleration rates?

The starting points are:

  - Teams that have performed a dynamic test, start out with a "B" (except where the standard IA is used).
  - Teams that have just use a crush (quasi-dynamic) test, start with a "C".
  - Teams that have tested a scaled down IA rather than a full size piece start with a "D". (The rationale for this can be found in the Frequently Asked Questions on the official SAE web site.)
  - Teams that performed only calculations and did not test get an "E".
  - Teams that did not turn in a report at all get an automatic "F". Errors in calculations and poor conclusions can result in the score being downgraded to an E or F
4. An evaluation of the overall content, format and quality of the report. A high quality report can be upgraded by one grade. A poor quality report can be downgraded by more than one grade if appropriate  
Further information on how IA reports might be graded can be found with the following link which is more applicable to when there was no IA form:  
[IA Report Grading.](#)

**ARTICLE 3: COST, MANUFACTURING AND SUSTAINABILITY EVENT Important Notice:** Additional information about the Cost and Manufacturing Event including Cost Tables and other information can be obtained from the [www.fsaeonline.com](http://www.fsaeonline.com) website which is also linked off the Formula SAE Rules and Important Documents page on the FSAE Website.

### **C3.1 Cost, Manufacturing and Sustainability Event Objective**

The objectives of the Cost, Manufacturing and Sustainability Event are:

- a. To teach the participants that cost and budget are significant factors that must be considered in any engineering exercise.
- b. For teams to make trade off decisions between content and cost based on the performance advantage of each part and assembly.
- c. To gain experience with creating and maintaining a Bill of Material (BOM).
- d. For the participants to learn and understand the principles of Design for Manufacture and Assembly, lean manufacturing and Minimum Constraint Design.
- e. To teach the participants that environmental impact is a significant factor that must be considered in any engineering exercise, particularly at the design stage.
- f. For teams to make trade off decisions between the performance advantage and environmental impact of the powertrain.

### **C3.2 Cost, Manufacturing and Sustainability Rules Objective**

The objectives of the Cost, Manufacturing and Sustainability Event rules are:

- a. To provide a logical, simple and time efficient rule set enabling students to achieve the event's objectives.
- b. To improve fairness by providing consistent pricing guidelines independent of team geographical location by using standardized Cost Tables.
- c. To require the minimal burden of supporting documentation such as receipts or catalogue pages. However, in order to convey design information to cost judges engineering documentation (drawings, process descriptions, etc.) are required.
- d. To improve fairness by providing consistent guidelines independent of teams' geographical location by using standardized material Eco data tables.
- e. To require the minimal burden of supporting documentation such as material suppliers environmental data sheets. However, in some cases there may be unusual materials used in components such as batteries, ultra-capacitors, fuel cells and composites that are not covered in the standard tables. In this case participants are encouraged to source the relevant embodied energy and CO2 information directly from the
- f. suppliers wherever possible and forward it to Formula Student Hungary Rules Committee for approval and inclusion in the materials database.

### **C3.3 Event Requirements**

This event is comprised of three (3) parts

#### **C3.3.1 Part 1 "Cost and Sustainability Report"**

The preparation and submission of a report (the "Cost and Sustainability Report"), which is to be sent to the Cost Judges prior to the competition. See C3.8.

#### **C3.3.2 Part 2 "Discussion"**

A discussion at the competition with the judges around the team's vehicle. See Section

C3.21. This evaluates not only the cost of the car, and sustainability assessment of the powertrain, but also the team's ability to prepare accurate engineering and manufacturing cost estimates.

#### **C3.3.3 Part 3 "Real Case"**

A "real case" scenario where students will have to respond to a challenge related to cost or manufacturing of the student vehicle.

### **C3.4 Formula SAE Michigan & Formula SAE Lincoln Reports - Not applicable for Formula Student Hungary**

### **C3.5 Cost Definitions**

The following definitions will apply throughout the Cost and Sustainability Event rules:

C3.5.1 Adjusted Cost - The final cost for the vehicle including penalties

C3.5.2 Amended Cost - The cost of the vehicle after modification by the competition addendum

C3.5.3 Bill of Material - A hierarchical list of all parts of the vehicle. A BOM lists every item that is on the vehicle but also shows the relationships between these items, for example showing the parts that make up an assembly. A Costed Bill of Material (CBOM) is a standard BOM that includes cost information including cost of purchased parts, raw materials and processes that go into manufacturing the vehicle. An Impact Bill of Material (IBOM) is a standard BOM that includes embodied energy and CO2 information for the materials that go into manufacturing the vehicle, a measure of the environmental impact of the components. (Applicable for powertrain only)

C3.5.4 Category - Each table has numerous entries which describe a classification of entry. For example there are several types of hose clamps, and all have various costs. The category of hose clamp may be worm drive, constant tension, etc.

C3.5.5 Cost - The cost for each item from the materials table is simply the quantity multiplied by the unit cost.

- C3.5.6 Cost & Sustainability Report - All materials submitted for judging as part of the cost and sustainability report, including an electronic and hard copy
- C3.5.7 Cost & Sustainability Score - Refers to the total number of points out of 100 earned in the Cost and sustainability event.
- C3.5.8 Cost Tables - All tables that list costs for objects and processes
- C3.5.9 Design for Manufacture and Assembly (DFMA) - The process where parts are designed for ease of manufacture and assembly, resulting in lower cost.
- C3.5.10 Fasteners Table - A Cost Table that consists of not only traditional fasteners such as bolts, nuts and rivets but also adhesives, hose clamps and retaining rings.
- C3.5.11 Fixed Cost - Costs associated with production that are independent of volume produced. Fixed cost items, such as tooling, are converted to variable costs when included in the Cost and Sustainability Report. 3.5.12 Initial Cost - The cost of the vehicle submitted for initial judging in the Cost and Sustainability Report.
- C3.5.12 Lean Manufacture - A methodology for producing goods that emphasizes the elimination of waste and improvement in process flow with the goal of optimizing the cost and quality of goods.
- C3.5.13 Materials Table - Lists the costs for raw materials used to manufacture parts built by the teams and also of finished parts purchased by the teams.
- C3.5.14 Minimum Constraint Design (MCD) - A design methodology emphasizing elimination of redundant constraints in the attachment of parts. Each part requires constraint in six degrees of freedom and additional constraints can make assembly difficult, force tight tolerances and increase the cost of manufactured goods.
- C3.5.15 Parameters - Used to create an equation describing the cost of an object as a function of some characteristic of that object. For example the cost of steel is proportional to the mass (or volume) of steel. In this case steel has been parameterized by mass. Rubber hose could be parameterized by diameter. The equations can be linear or non-linear and both 1st and 2nd order equations are used as necessary to build the Cost Tables.
- C3.5.16 Process Multipliers - Modify the standard costs of different operations to account for material and geometric differences in the part.
- C3.5.17 Purchased Parts - Also called bought parts; these items are listed in the Cost Tables in a near as-installed condition. For example wheels, engines and turbochargers are purchased parts. In some cases purchased parts may still require additional processing before they can be assembled to the car. Wheels, for example, do not include the machined features for mounting to the hub. Purchased parts do not include fasteners unless specifically noted in the Cost Tables.
- C3.3.18 Sustainability Materials List - Lists the mass-based embodied energy and CO2 values for raw materials used to manufacture parts built by the teams, bought-in components where data is available and a class of residual material to cover bought-in components that cannot be easily accounted for due to a lack of material composition data The residual material is also used for calculating penalties.
- C3.5.19 Quantity - The amount of the item gross or net as applicable.

- C3.5.20 Raw Materials - Materials used for manufacturing parts, such as aluminium, steel and rubber hose.
- C3.5.21 Tools - Tools refer to hand or power tools used to assemble the vehicle. The costs of these tools are not included in the Cost & Sustainability Report. The effect of the tools used for assembly are captured in the process tables for labour as different costs are given based on the tools used for assembly.
- C3.5.22 Tooling - Is the production tooling associated with processes that are specific to the part geometry. The costs of tooling must be included in the Cost and Sustainability Report. For example the dies to stamp out a chassis bracket are tooling. The press used to stamp the bracket is not, and is considered production equipment which is not part of the Cost Event.
- C3.5.23 Unit - Is the measurement system used to define the quantity of a parameter. For example millimetres and kilograms are units. The hose clamp diameter unit is mm. When calculating the cost of the clamp the unit of measurement used by the team must match the Unit specified in the tables. For example a US team mistakenly calculates the hose clamp cost by using the expression with a diameter of 1, because their radiator hose is 1 inch in diameter. They should have used 25.4mm for the diameter and their cost is wrong because of it. For the penalties associated with this type of error see C3.18
- C3.5.24 Unit Cost - Is the cost for something assuming a numerical value of one (1) of the unit used to measure the item. The cost is the quantity of an item multiplied by the unit cost.
- C3.5.25 Variable Cost - Is a cost associated with production that is proportional to the vehicle volume produced. All costs submitted with the Cost and Sustainability Report will be variable costs.
- C3.5.26 Eco data - Data relating to the properties of a material which have an impact upon the surrounding environment during its production, use and disposal, such as embodied energy/CO<sub>2</sub>, toxicity, biodegradable, renewable etc.
- C3.5.27 Eco-Design - The process by which items are designed for minimum environmental impact by careful consideration of form and materials selection.
- C3.5.28 Environmental Impact - The environmental impact for each item is simply the mass of the constituent materials that make up that item multiplied by the unit energy and CO<sub>2</sub> values for those materials from the Sustainability Materials List.
- C3.5.29 Initial Environmental Impact - The environmental impact of the vehicles powertrain submitted for initial judging in the Cost and Sustainability Report.

### **C3.6 General Requirements**

C3.6.1 The Cost and Sustainability Report must:

Use the standardized Cost and Sustainability Tables. The tables are designed to reflect a hypothetical car built for production at the annual volume of 100 units per year.

- a. List and cost every part on the prototype vehicle. This includes any equipment fitted on the vehicle at any time during the competition.  
The only exceptions are that, per C.3.22 “Cost and Sustainability Report Exempt Items” of the Rules, the cost of any finish, on-board fire suppression system, rain tires, video or radio system, does not need to be included in the Cost and Sustainability Report.
- b. Be based on the estimated costs of materials, fabrication, purchased parts, and assembly of the car. The costs shall be calculated as defined in these rules.
- c. Be based on the actual manufacturing technique used on the prototype, e.g. cast parts on the prototype must be cost as cast, and fabricated parts as fabricated, etc.
- d. Include tooling (e.g. welding jigs, moulds, patterns and dies) for processes requiring it.
- e. Exclude R & D and capital expenditures (e.g. plant, machinery, hand tools and power tools). Note: There is no maximum cost. Receipts are not required for any items.

C3.6.2 The Cost and Sustainability Tables have been designed to:

- a. Be verifiable at the event. Differentiating between different types of materials (for example different alloys of steel) is not possible so no differentiation is made in the table cost.
- b. Minimize influence on safety equipment content. For example driver harnesses are cost independent of the style chosen.
- c. Higher costs of some goods must reflect actually higher value of those goods. However, the costs must still allow for team innovation and vehicle content, with some reduction in cost score.
- d. Include net weight for powertrain components and as accurate a possible a split for the subsequent materials
- e. For combustion engines, typical data will be provided in the data tables
- f. To support BEV, please provide split of materials, steel, copper, brass etc. as appropriate to support your presented documentation and assessment of powertrain sustainability.

C3.7 Scoring

The points for the Cost and Sustainability Event will be broken down as follows:

$20 \times \left[ \frac{P_{\max}}{P_{\text{your}}} - 1 \right]$ $\left[ \frac{P_{\max}}{P_{\min}} - 1 \right]$	20	Lowest cost - each of the participating schools will be ranked by total adjusted cost from the BOM and given 0-20 points based on the formula on the left.
	40	Accuracy, Clarity & Event Day/Visual Inspection - The cars will be reviewed for part content, manufacturing feasibility and accuracy of the cost information. Supporting documentation will be assessed based on its quality, accuracy and thoroughness. The range for the score is 0-40 points.
	20	Event Day/Manufacturing Processes - The teams must be prepared to discuss in detail the "real case" scenario distributed prior to the competition. The materials will include more specifics about the goal and scoring of the scenario. The range for the score is 0-20
	20	Teams judged on presentation of the selection process for powertrain and the consideration for associated embedded CO <sub>2</sub> . Figures calculated based on KWh and KW for BEV, and embedded CO <sub>2</sub> for combustion engines.
Total	100	

$P_{\text{your}}$  is the adjusted cost of your car (with penalties) in dollars.

$P_{\min}$  is the adjusted cost of the lowest cost car in dollars.

$P_{\max}$  is the cost of the highest cost car in dollars.

### C3.8 Cost and Sustainability Report

C3.8.1 The Cost and Sustainability Report consists of a full vehicle BOM with cost data derived from the Cost Tables and supporting documentation. The Cost and Sustainability Report must be submitted in two (2) forms:

- a. Electronic Version - The electronic version must be identified as follows:
  - a. Carnumber\_schoolname\_competitioncode\_SR.xlsx using the assigned car number,
  - b. The complete school name and the competition code. Example: 500\_University of FSAE\_FSH\_SR.xlsx, Competition Codes are listed in Rule A2.6
- b. Hard Copy - The hard copy Cost and Sustainability Report must be in a ring binder with A4 pages, and no more than 1 folder

#### C3.8.2 Cost and Sustainability Report Identification

The cover of the Cost and Sustainability Report must include the following:

- a. university name,
- b. competition name, and
- c. Vehicle number.

C3.8.3 The Cost and Sustainability Report must consist of the following:

- A Cover sheet
- A Table of Contents
- A Cost Summary page listing each section's cost, and the total vehicle cost
- Eight commodity report sections with the parts placed in the sections as specified in FSAE rules Appendix C-3.
- Tabs for each section
- The sustainability figures as provided related to the powertrain.

Note: Teams entered into a competition using the Cost Application (See C3.24) should still include the items above but the cost summary pages can be printed directly from the application.

C3.8.4 Scoring and judging of the sustainability element of the competition will be split into two areas to achieve the maximum 20 points.

- a. Firstly an embedded CO<sub>2</sub> score out of 10 derived from the embedded CO<sub>2</sub> tables will be given. The students must provide for BEV, hybrid or other non-combustion engine powertrains the material split by weight or % of weight of the powertrain for all items defined as powertrain. For Combustion engines, the engine CC and powertrain system weight for all items defined as powertrain must be submitted. (see Appendix C1 for definition). Any items required for powertrain to function not listed in Appendix C1 must be submitted as an add item as per C3.13.3.
- b. Secondly, a presentation at the event (not submitted prior) on the rationale for powertrain selection, demonstrating the sustainable impact as a result of that decision.

### **C3.9 Bill of Materials (BOM)**

The BOM is a parts list for every vehicle part. It also shows the relationships between the items.

C3.9.1 The following terminology will be used when referring to the BOM.

The overall vehicle is broken down into eight (8) systems which are defined in FSAE Rules Appendix C-3. Systems are made up of Assemblies. Assemblies are made up of Parts. Parts consist of materials, processes and fasteners.

C3.9.2 An example BOM structure is shown below:

- Engine & Drivetrain ..... System
- Engine ..... Assembly
- Differential ..... Assembly
  - Housing ..... Part
  - Aluminium ..... Material
  - Needle Bearing ..... Material
  - Sand cast ..... Process
    - Die & Core Package #4 ..... Tooling
  - Machining-Turn ..... Process
  - Weld ..... Process
  - M6x1.25 Grade 8.8 ..... Fastener
- Internals ..... Part
- End Cap ..... Part

The BOM must follow the format given above. There must be no other BOM levels added or any removed. Deviations from the structure published will be penalized per Section C3.17.

C3.9.3 All assemblies, parts and fasteners in the BOM must use a standard numbering convention explained in FSAE rules Appendix C-2.

**C3.10 The Cost and Sustainability Tables**

C3.10.1 All costs in the Cost and Sustainability Report come from the standardized Cost Tables and Sustainability Tables. These tables have been compiled to represent the cost of parts and processes that a manufacturing company could be expected to pay for manufacturing a vehicle at 100 units per year. Generally, the tabulated value represents 1/2 of the Manufacturer's Suggested Retail Price (MSRP) for finished parts. Raw materials, commodities and fasteners also intended to represent the production volume of a company rather than the purchase price of the University teams. The sustainability tables are predefined to provide comparable data for embedded CO<sub>2</sub> for the powertrain.

C3.10.2 Requests to alter the cost of goods in the tables because of changing world markets or individual team purchase price will not be approved. The tables are intended to provide a fair, unchanging (within a given competition year) cost for parts and to reduce regional variations in price that may help or hurt certain teams. All teams must use the costs given in the tables. If a team wishes to use any parts, processes or materials not included in the tables an "Add Item Request" must be submitted as per Section C3.13.

C3.10.3 The tables represent cost based on specific parameters. For example the cost of steel is given per unit of volume (or mass). Likewise, engine costs are listed by displacement and specific power output.

- C3.10.4 The following Cost Tables are used
- Materials
  - Processes
  - Process Multipliers
  - Fasteners
  - Tooling
- C3.10.5 In general, most items have a cost expressed as a function of one parameter. In cases where more than one parameter is necessary additional categories are listed. For example the power output of the engine has three Categories and for each Category a different expression calculates the cost as a function of the engine displacement, which is the Parameter. The Unit would be cubic centimetres in this case.
- C3.10.6 Process Multipliers are used to modify the standard costs of different operations to account for material and geometric differences in the part. For every process included in the Cost and Sustainability Report the list of process multipliers must be checked to determine if any apply, and if they do their effect on the cost must be included.
- C3.10.7 When adding items from tables to the BOM the comments section should be reviewed thoroughly to understand what is included in the table entry. For example is the spring included in the damper cost? Do the spark plugs come with the engine or are they a separate line item? In cases where the explanation is not clear please contact the Rules Committee for clarification.
- C3.10.8 All environmental impact figures in the Sustainability Report come from the standardized Sustainability Materials List. This list has been compiled to represent the average embodied energy and CO<sub>2</sub> values for raw materials and a limited number of bought-in components used in the manufacture of the vehicle.
- C3.10.9 It should be noted that the Eco data provided is not precise in the same sense as other technical material properties such as stiffness and strength. Eco data is by its nature both regional and subject to variation over time as technology for material extraction and processing evolves. The figures quoted are the mean of available data where the max-min may be a variation of +/- 25%
- C3.10.10 Requests to alter the embodied energy and CO<sub>2</sub> values of materials in the list because of changing technologies and processes will not be approved. The list is intended to provide a fair, unchanging (within a given competition year) environmental impact for materials and to reduce regional variations that may help or hurt certain teams. All teams must use the embodied energy and CO<sub>2</sub> values given in the list. If a team wishes to use any materials not included in the list an "Add Material Request" must be submitted to the Formula Student Hungary Rules Committee, see C3.13.3.
- C3.10.11 The list represents embodied energy and CO<sub>2</sub> based on material mass.
- C3.11 Cost Models & Costing Methodology**  
The cost models are the underlying methodology and equations that relate the final cost of a part or process to the different operations and goods used in that part. The detailed explanation of the Cost Models and Costing Methodology is included in FSAE rules Appendix C-1 and should be referenced for understanding the use of the Cost Tables.
- C3.12 Make Versus Buy**  
Every part on an individual car can be classified as "made" or "bought". This designation does not necessarily refer to whether a team actually purchased or fabricated a part but is a reflection of how the part must be cost from the Cost Tables.

- a. Made (or manufactured) parts must be cost as if the company manufacturing the vehicle was going to make the part internally. That is by purchasing raw materials and processing them into a finished product.
- b. Bought parts must be cost as if the company manufacturing the vehicle was going to outsource the fabrication of that part. These parts would be received by the vehicle manufacturer in a relatively finished state (see the particular table entry comments field for specific information).

C3.12.1 The Cost Tables have been constructed as a trade-off between complexity for the organizers and fairness for the teams. The make versus buy designation enables certain parts to be simplified to a relatively few number of entries. For example some teams may purchase axles but the majority of teams manufacture them. Axles are designated “make” parts so teams that purchase axles must cost them as if they had made them starting with the raw materials, in this case probably steel tubing. Made parts can be distinguished because they do not appear explicitly in the Cost Tables or appear with a “cost as made” option.

C3.12.2 If a team genuinely makes a part listed on the table as a bought part they may alternatively cost it as a made part if and only if a place holder entry is listed in the tables enabling them to do so. For example, in the category of dampers a “student built” entry is included. This line item must be included in the BOM (it has zero cost). Then they must proceed to cost the damper they actually designed and built.

C3.12.3 A table summary of options is given below:

	How Team Actually Acquired the Part	
How Table Lists Part	Team Made	Team Bought
Table Lists Part as "Made", or Part is not Listed in the Tables	Cost as "Made"	Cost as "Made"
Table Lists Part as "Bought"	Team made option NOT in table cost as "Bought". If team made option in table team can choose either "Bought" or "Made"	Cost as "Bought"

C3.12.4 For example a snap ring does not have a “team made” entry in the Cost Tables. A team who made their own would still have to use the table cost based on diameter, even if they could cost it less expensively by buying steel and processing it.

C3.12.5 Any part which is normally purchased that is optionally shown as a made part must have supporting documentation submitted to prove team manufacture. This might include engineering drawings, pictures of machining, etc. Teams found costing bought parts as made parts will be penalized appropriately.

### C3.13 Add Item Request

C3.13.1 The costs tables are intended to include all materials, processes and fasteners needed by the teams to accurately reflect the content, manufacture and assembly of their vehicle. However, it will be necessary to add items to the tables to suit individual team requirements. To do this an “Add Item Request” must be submitted to the Rules Committee.

After review the item will be added to the tables with the next table update with a cost appropriate to the overall Cost Table framework and spirit of the competition. The tables will be updated throughout the competition year as required.

C3.13.2 The form should be completely filled out and contains the necessary instructions. Some supporting documentation will be required such as receipts or website links. The Add Item request is the only time receipts will be needed for the Cost Event. Note: Since all teams work off the same tables once a team requests an item be added to the tables all teams will see the addition. Any team using the newly added item will use the same cost. The identity of the school that made the request will not be published.

C3.13.3 For “add items” as part of sustainability (specific to equating and calculating embedded CO<sub>2</sub>), students submit requests under the ‘sustainability’ section of the FSQD website. These are then reviewed and added as required.

### **C3.14 Report Submission and Deadline**

- a. The Cost and Sustainability Report must be submitted in the designated format for each event.
- b. For some events, a printed copy of the report must also be submitted and must be on 8 1/2 inch x 11 inch or A4 size paper, using a 10-point font size or larger.
- c. Submission Address and Deadline - The submission requirements, address and deadline will be published in the appendix or released on the website of the specific competition.

### **C3.15 Late Submission of Cost and Sustainability Report**

It is imperative that the cost judges have the Cost and Sustainability Reports in enough time for proper evaluation. Teams that submit reports late will be penalized 10 points per day late, with a maximum penalty of 80 points. Teams that do not submit a Cost and Sustainability Report will receive negative 100 points for the Cost & Manufacturing Analysis score. Penalties will be applied based on official upload date and time for electronic submission and by post mark for printed submissions.

### **C3.16 Addenda**

C3.16.1 An addendum that reflects any changes or corrections made after the submission of the Cost and Sustainability Report must be submitted at Registration when the Team registers on-site at the Event. It will not be accepted at any other time or place. The addendum document must follow the template format specified in FSAE rules Appendix C-5. No other format will be accepted.

C3.16.2 Addenda apply only to the competition at which they are submitted. A separate addendum is permitted for every competition a vehicle attends.

C3.16.3 Any items added to the Cost and Sustainability Report through addenda will be cost at 1.25 times the table cost. Any items removed through addenda will only be credited 0.75 times the table cost.  
Note: Late changes to designs impact costs in the real world. Contracts need to be altered, commodity costs can change, cancellation fees may be incurred and information needs to be transmitted to suppliers. The scaling factors for the addenda capture this as well as encourage teams to submit full and accurate information with the initial Cost and Sustainability Report.

### **C3.17 Cost and Sustainability Report Judging and Penalties Process**

C3.17.1 The following procedure will be used in determining penalties:

1. Penalty A will be calculated first using procedure C3.18
2. Penalty B will then be calculated using alternative procedure C3.19

3. The greater of the two penalties will be applied against the cost score
  - a. Penalty A expressed in points will be deducted from the Accuracy score
  - b. Penalty B expressed in dollars will be added to the Adjusted Cost of the vehicle
4. If no additional points remain to be deducted from the Accuracy score the penalty will be applied using method B against the Adjusted Cost

C3.17.2 If the alternative penalty is used because no additional accuracy points remain then the highest of the A type penalties will be converted to B type penalties. In effect, the order the penalties are calculated and applied against the team does not matter.

C3.17.3 Any error that results in a team over reporting a cost in their Cost and Sustainability Report will not be further penalized. For example, when the Cost and Sustainability Report is prepared the thickness of the brake rotors has not yet been determined. The team conservatively costs the rotors as 10mm thick. The final thickness is 8mm and no change is made in the addendum. The team rotor price is higher than necessary but no penalty is applied.

**Note:** The penalty system is intended to reward accuracy and minimize workload at the competition for students and judges. In most cases the standard point's deductions will be made to the accuracy score.

**Note:** Any instance where a team's score benefits by an intentional or unintentional error on the part of the students will be corrected on a case by case basis.

### C3.18 Penalty Method A- Fixed Point Deductions

C3.18.1 From the Bill of Material, the cost judges will determine if all parts and processes have been included in the analysis. In the case of any omission or error the judges will add a penalty proportional to the BOM level of the error. The following standard point's deductions will apply:

- Missing/inaccurate material, process, fastener ..... 1 pt.
- Missing/inaccurate part..... 3 pt.
- Missing/inaccurate assembly ..... 5 pt.

Note: Each of the penalties listed above supersedes the previous penalty. If a 5 point deduction is given for a missing assembly the missing parts are ignored for Method A. Method B would include the cost of the missing parts in the calculation.

C3.18.2 Differences other than those listed above will be deducted at the discretion of the cost judges.

Examples of errors leading to points deductions:

- Five M6 fasteners listed, six used - 1 pt.
- Three kilograms of steel listed, 4.4 used - 1 pt.
- Bearing carrier face machined, mill operation not included - 1 pt.
- Installation labour for steering wheel missing - 1 pt.
- Upright cost as cast but actual part billet machined - 3 pt.
- Pneumatic shifter not included on BOM - 5 pt.

The penalties above will be deducted from the points awarded for Accuracy of the Cost and Sustainability Report.

### **C3.19 Penalty Method B - Adjusted Cost Deductions**

The alternative penalty will be calculated using the following equation:  $\text{Penalty} = 2 \times (\text{Table Cost} - \text{Team Reported Cost})$

The table cost will be calculated from the standard Cost Tables. The penalty calculation will result in a dollar value equal to twice the difference between the team cost and the correct cost for all items in error.

This penalty, if applied, will be made to the Adjusted Cost of the vehicle. Note: The table costs of all items in error are included in the calculation. A missing assembly would include the price of all parts, materials, processes and fasteners making up the assembly.

### **C3.20 Penalty Calculation Example**

For example the pneumatic shifter was inadvertently left off the Cost and Sustainability Report. As this is an assembly the standard error is 5 points. The cost of all air shifter parts and processes from the Cost Tables is \$500. This means the total penalty cost is \$1000. To see which is greater, 5 points or \$1000, the dollar penalty needs to be converted to points by reference to the Cost Points formula:

$$\text{Points} = 20 \times \frac{[(P_{\text{max}})/(P_{\text{your}}) - 1]}{[(P_{\text{max}})/P_{\text{min}}] - 1}$$

Substitute the cost of the vehicle ( $P_{\text{your}}$ ) with \$15,000 while the minimum vehicle cost ( $P_{\text{min}}$ ) was \$10,000. The maximum vehicle cost ( $P_{\text{max}}$ ) was \$50,000. Calculating the point's equivalent for this dollar amount yields 2.5 points. This is less than the standard penalty. In this case the 5 points would be deducted from the Accuracy score.

If the team had made many small errors and had no more accuracy points available then the \$1000 would be added to the team's adjusted cost.

### **C3.21 Discussion at the Competition**

C3.21.1 At this discussion, the Cost Judges will:

- a. Review whether the specification of the vehicle in the Cost and Sustainability Report accurately reflects the vehicle brought to the Competition
- b. Review the manufacturing feasibility of the vehicle
- c. Assess penalties for missing or incorrect information in the Cost and Sustainability Report compared to the vehicle presented at inspection.
- d. Assess the students understanding, concept and reasoning for the chosen powertrain, and their presentation competence of the subject matter.

C3.21.2 The team must present their vehicle at the designated time to the Cost Judges for review of the Cost and Sustainability Report. Teams that miss their cost appointment will potentially lose all cost points for that day. The schedule for these appointments will be in the registration packets and/or posted on the website.

### **C3.22 Cost and Sustainability Report Exempt Items**

C3.22.1 Finishes

The car will be considered to be shipped as primed or gel coated and a cost recorded. Any finishes (paint, polish, etc.) that are only used to beautify need not be costed. Preservative finishes intended to protect the appearance or function of a part for an extended period of time must be costed (labour and material included).

C3.22.2 Fire Extinguisher and Suppression System

Hand held fire extinguishers are not allowed on the vehicle (See Rule B17.2 "Fire Extinguishers"), but if the car has an on-board fire suppression system, it is not required to be costed.

- C3.22.3 Tires and Wheels**  
Only one set of tires and wheels needs to be included in the Cost and Sustainability Report. The tires and wheels that are declared as dry tires per rule B6.4 “Tires” must be the tires included in the Cost and Sustainability Report, and must be the tires on the car during the Cost Event judging. Other tires that will be potentially used at the competition (i.e. rain tires) do not need to be included in the Cost and Sustainability Report. C3.22.4 Transponders, Video and Radio Systems
- Transponders, video and radio systems, need not be included in the Cost and Sustainability Report.
- C3.22.5 Data Acquisition Systems**  
Data acquisition systems must be included in the Cost and Sustainability Report using the published table costs. This includes display screens, control modules and all sensors. The table costs for control modules and screens have been set to match an equivalent product without the data acquisition functionality. In essence, “stand-alone” data acquisition systems excluding sensors and wiring will have no influence on vehicle cost. Systems that include driver displays or other vehicle control functionality will have the cost of those features included in the total vehicle cost.
- In summary, all data acquisition systems, sensors and wiring must be included in the Cost and Sustainability Report using the Cost Table prices.
- C3.23 Exchange Rates & Unit Systems**  
The currency of the Cost and Sustainability Report will be referred to as dollars. Since all items have a cost from the Cost Tables the actual currency unit is irrelevant.
- C3.23.1** All Cost Tables are presented using metric units. The tables do not differentiate between parts designed in metric and US systems of measure. For example a % bolt is simply input as a 6.35mm bolt. Tubing with a wall thickness of 0.035 inches is input as 0.889mm tubing. All sizes are assumed to be standard for the part being cost and no surcharge applies for any size, even if the size is non-standard. For example a team makes a custom 6.112mm bolt which took several hours of student time. However, this bolt is chosen from the Cost Tables and is less than one dollar. The assumption is in high volume production these bolts would be purchased in bulk.
- C3.23.2** The comment section for each material, process or fastener may, at the student’s discretion, refer to the specific part by actual local designation. For example a 6.35mm bolt is cost but the comments would say “1/4 inch A-arm bolt”.
- C3.23.3** Because the Cost and Sustainability Report reflects a production cost for 100 units per year all material and commodity sizes are assumed to be available for the necessary volume without cost penalty.

#### **ARTICLE 4: BUSINESS PRESENTATION EVENT**

##### **C4.1 Business Presentation Event Objective - Business Case**

- C4.1.1** The objective of the business presentation event is to evaluate the team’s ability to develop and deliver a comprehensive business case that will convince the executives of a corporation that the team’s design best meets the demands of the amateur, weekend competition market, including Sports Car Club of America (SCCA) Solo, and that it can be profitably manufactured and marketed. (See also A1.2)

- C4.1.1.a Teams are not required to assume a production rate of 1000 cars per year. It is therefore open to teams to suggest a proposed market size and corresponding manufacturing volume / production run targets. The important element is that teams demonstrate the logic behind their assumption / proposal and are also able to demonstrate that it can support a viable business model for both parties.
- C4.1.2 The business presentation event is a role play and teams should present themselves as employees of a company rather than as students. The judges should be treated as if they were executives of a corporation interested in either manufacturing your design or investing in your company. Teams should approach the event with a view to obtaining a business deal to manufacture and sell the team's car
- C4.1.3 Teams should assume that the "executives" represent different areas of a corporate organization, including engineering, production, marketing and finance, and thus may not all be engineers.
- C4.1.4 Presentations will be evaluated on the contents, organization and visual aids as well as the presenters' delivery and the team's response to questions.
- C4.1.5 The presentation must relate to the car entered into the competition although the actual quality of the prototype itself will not be considered as part of the presentation judging.
- C4.2 Business Presentation Schedule**
- C4.2.1 Presentations will be made on the static events day. Presentation times will be scheduled by the organizers and either, or both, posted in advance on the competition website or released during on-site registration.
- C4.2.2 Teams that fail to make their presentation during their assigned time period will receive zero (0) points for the event.
- C4.3 Business Presentation Format**
- C4.3.1 One or more team members will give the presentation to the judges.
- C4.3.2 All team members who will give any part of the presentation, or who will respond to the judges' questions, must be in the podium area when the presentation starts and must be introduced to the judges. Team members who are part of this "presentation group" may answer the judge's questions even if they did not speak during the presentation itself.
- C4.3.3 Presentations are limited to a maximum of ten (10) minutes. A penalty will be imposed if the presentation exceeds 12 minutes or if the presentation is excessively short in duration. Teams will be asked to rapidly conclude their presentation if they overrun significantly.
- C4.3.4 The presentation itself will not be interrupted by questions. Immediately following the presentation there will be a question and answer session of up to five (5) minutes.
- C4.3.5 Only judges may ask questions. Only team members who are part of the "presentation group" may answer the judges' questions.
- C4.3.6 For the convenience of the Business Presentation Event judges, in all Classes, teams giving a PowerPoint or similar style presentation are required to hand a paper copy of their slides, preferably in colour, to the judges at the end of the Question and Answer session.

- C4.4 Audio-Visual Display Equipment**
- C4.4.1 LCD / Plasma TV-style screens will be provided by the organisers (no OHPs will be provided), but teams should bring their own laptop computers and may use their own projectors if they wish. Teams are responsible for the compatibility of their computer equipment and setting up of the screens. Overseas teams should ensure they have UK compatible power leads/adaptors.
- C4.5 Evaluation Criteria**
- C4.5.1 The scoring criteria differs slightly from the FSAE scoring with additional weighting given to Content (40% of the marks are allocated to Content, the remaining marks are equally allocated to Organisation, Visual Aids, Delivery and Q&A). The detailed scoring sheet is not published but the broad topics are in line with the standard FSAE scoring sheet
- C4.5.1a The Business Presentation should also briefly address the environmental credentials of the project and proposed vehicle. This will be assessed under the 'Content' section of the Business Presentation. This is not to be confused with the Sustainability static event and its associated presentation.
- C4.5.2 The criteria are applied only to the team's presentation itself. The team that makes the best presentation, regardless of the quality of their car, will win the event.
- C4.6 Scoring Formula**
- C4.6.1 The Business Presentation Events score is based on the average of the judges' scores.
- C4.6.2 The Business Presentation scores will be normalised such that the highest scoring presentation scores 75 points towards the overall competition score, and all other teams will be awarded points on a prorata basis.
- BUSINESS PRESENTATION SCORE =  $75 \times P_{\text{your}}/P_{\text{max}}$  Where:  
"Pmax" is the highest score awarded to any team  
"Pyour" is the score awarded to your team
- C4.6.3 It is intended that the scores will range from near zero (0) to seventy-five (75) to provide good separation.
- C4.6.4 The Business Presentation Event Captain may at his/her discretion; normalize the scores of different judging teams.
- C4.7 Business Presentations without a Completed Car**
- Teams that unable to bring a vehicle to the competition may participate in the Business Presentation Event and will receive a score for that event.
- Note: Participating in the Presentation event without bringing a vehicle to the competition will not affect the status of the car you have under construction at your school. When you finish it and bring it to a competition it will still be a first year vehicle under Rules A6.6 and A6.8

## ARTICLE 5: DESIGN EVENT

- C5.1 Design Event Objective**
- C5.1.1 The concept of the design event is to evaluate the engineering effort that went into the design of the car and how the engineering meets the intent of the market.
- C5.1.2 The car that illustrates the best use of engineering to meet the design goals and the best understanding of the design by the team members will win the design event.

**Comment:** Teams are reminded that FSAE is an engineering design competition and that in the Design Event teams are evaluated on their design. Components and systems that are incorporated into the design as finished items are not evaluated as a student designed unit, but are only assessed on the team's selection and application of that unit. For example, teams that design and fabricate their own shocks are evaluated on the shock design itself as well as the shock's application within the suspension system. Teams using commercially available shocks are evaluated only on selection and application within the suspension system.

You are respectfully reminded that consideration of cost (manufacturing, service and parts) is a Design parameter. Design for manufacture is a specific area that will be assessed. The influence of likely tooling costs and the intended production volumes are also Design considerations.

**C5.2 Design Report - Required Submission**

C5.2.1 Design Report - Judging will start with a Design Review before the event. The principal document submitted for Design Judging is a Design Report.

C5.2.2 The Design Report must not exceed eight (8) pages, consisting of not more than four (4) pages of text, three (3) pages of drawings (see C5.4, "Vehicle Drawings") and one (1) optional page containing content to be defined by the team (photo's, graphs, etc...). See also C5.5.5 and C5.5.6

C5.2.3 The document should contain a brief description of the vehicle with a review of your team's design objectives, a discussion of any important design features and vehicle concepts. Include a list of different analysis and testing techniques (FEA, dynamometer testing, etc.). Evidence of this analysis and back-up data should be brought to the competition and be available, on request, for review by the judges.

C5.2.4 These documents will be used by the judges to grade teams into the appropriate design groups based on the quality of their Design Report. See also A8.5.

**Comment:** Consider your Design Report to be the "resume of your car".

**C5.3 Design Spec Sheet - Required Submission**

C5.3.1 Design Spec Sheet - A completed FSAE Design Spec Sheet must be submitted.

C5.3.2 The FSAE Design Spec Sheet template can be found at [www.fsaeonline.com](http://www.fsaeonline.com). Do not alter or re-format the template prior to submission.

C5.3.3 The design judges realize that final design refinements and vehicle development may cause the submitted figures to diverge slightly from those of the completed vehicle. For specifications that are subject to tuning, an anticipated range of values may be appropriate.

C5.3.4 The Design Report and the Design Spec Sheet, while related, are independent documents and must be submitted as two (2) separate files.

**C5.4 Vehicle Drawings**

C5.4.1 The Design Report must include one set of three (3) view drawings showing the vehicle, from the front, top, and side.

C5.4.2 Each drawing shall appear on a separate page. The drawings can be manual or computer generated.

C5.4.3 Photos should be placed on the optional page and will not be counted as drawings.

## **C5.5 Design Report and Design Spec Sheet Formats**

C5.5.1 The Design Report must be submitted electronically in Adobe Acrobat® Format (\*.pdf file). This document must be a single file (text, drawings, and optional content all inclusive).

C5.5.2 The Design Report file must be named as follows:  
carnumber\_schoolname.pdf using the FSAE assigned car number and the complete school name, e.g. 001\_University of SAE.pdf

C5.5.3 Design Spec Sheets must be submitted electronically in Microsoft Excel® Format (\*.xls file). The format of the Spec Sheet **MUST NOT** be altered.

C5.5.4 Similar to the Design Report, the Design Spec Sheet file must be named as follows:  
carnumber\_schoolname\_specs.xls using the FSAE assigned car number and the complete school name, e.g. 001\_University of SAE\_spec.xls

WARNING - Failure to exactly follow the above submission requirements may result in exclusion from the Design Event. If your files are not submitted in the required format or are not properly named then they cannot be made available to the design judges and your team may be excluded from the event.

C5.5.5 For the convenience of the judges, Design Reports must be a minimum of 10 point black font (preferably Arial or Verdana), formatted for A4 portrait paper size, with text in one column per page (i.e. no newspaper style columns) and with a maximum word count of 2500 words. This word count must be declared at the end of the text section of the Report. Text pages must be text only, i.e. without graphics integrated within the body of the text. The optional page (FSAE Rule C5.6) can be used for graphics (referenced from the main text) if necessary. This optional page cannot be used as a continuation of the text pages if this would take the total number of text pages above the 4 page limit also specified in FSAE Rule C5.5.2.

To further encourage teams to pay full and proper attention to the Design Report, the Design event score (150 points in all classes) will be split such that 10 points are allocated for the pre-submitted Report and the remaining 140 points for the at-event judging. These points (0-10) will be allocated by the judges prior to the event and will be based entirely on the technical content of the report and how well that content meets the design event objective (as defined in FSAE Rules).

Design Reports for Class 1 must be submitted fully in accordance with the FSAE Rules regarding file names. Note the car must be numbered using 3 digits e.g. car 2 labelled 002. Class 2 teams should follow the same requirements except replace "car number" with "Class 2 Uni Name" as appropriate. Please note it is anticipated that the webserver will, as in 2011, automatically allocate the filename in the correct format: only the latest upload will be assessed as a valid submission. Please see late submission penalties C5.9.

**Penalties** for formatting errors will be applied separately, to the overall event score, as follows (capped to a maximum negative 20 points):

- Page Layout:
  - More than a total of 8 pages (including cover sheets etc.) negative 15 points
  - Over 4 pages text negative 2 points Newspaper style columns negative 2 points
  - Integrated graphics negative 2 points
- File name format:
  - Incorrect file name or format negative 5 points
- Report Structure:
  - Minor errors (e.g. all drawings on 1 page, no word count) negative 2 points
  - Serious errors (e.g. no drawings) negative 5 points

#### C 5.5.6 Design Spec Sheets

A penalty may be applied to the overall event score, for the failure to use the correct template form and to teams that, in the sole opinion of the judges, have failed to complete the specification sheet adequately: maximum negative 10 points.

#### C5.6 Excess Size Design Reports

If a team submits a Design Report that exceeds four (4) pages of text, three (3) pages of drawing and one (1) optional page, then only the first four pages of text, three pages of drawings and first optional page will be read and evaluated by the judges. Note: If included, cover sheets and tables of contents will count as text pages.

#### **C5.7 Student Activity Disclosure - Required Submission**

C5.7.1 A "Student Activity Disclosure Form" detailing the distribution of the design, manufacturing and assembly of the vehicle between members of the team and non-members must be submitted. The standard Disclosure Form available on the FSAE website must be used.

The Disclosure Form is a required Design Document and subject to the submission deadlines and penalties found in Rule C5.8 "Submission Deadlines" and Rule C5.9 "Penalty for Late Submission or Non-submission". The Student Activity Disclosure Form is posted at [www.fsaonline.com](http://www.fsaonline.com).

C5.7.2 Definitions: For the purposes of completing the Student Activity Disclosure Form the following definitions will apply:

C5.7.3 Team Designed - "Team Designed" states that the team designed the component to be manufactured from raw materials to meet a project goal and/or to comply with a requirement of the FSAE Rules. Designed components may incorporate commercially manufactured parts, e.g. bearings, fasteners, gears, sensors, electronic components, etc. provided that the final "design" reflects the thinking of the team and was designed to meet a team defined purpose. Remanufacturing a component to a design developed by a previous team is not considered to be a "design" by the current team.

C5.7.4 Team Manufactured - "Team Manufactured" states that the team members performed the actual hands-on work of fabricating the component from raw materials, or subcomponents, through the use of one or more fabrication processes including, but not limited to: bonding, casting, cutting, curing, drilling, hardening, laminating, machining, polishing, riveting and welding. Any components produced by non-team members, including school machinists or welders, outside machinists or welders, sponsors or others are not considered to have been "manufactured" by the team. Please note that assembling commercially available parts alone, without "manufacturing" any part from raw materials is assembling not manufacturing.

C5.7.5 Team Assembled - "Team Assembled" states that the team members assembled the component, or section of the vehicle, from smaller pieces and/or subcomponents through the use of one or more assembly and fastening processes including, but not limited to: brazing, bolting, gluing, screwing, welding and wiring.

#### **C5.8 Submission Deadlines**

C5.8.1 The Design Report, the Design Spec Sheets and the Student Activity Disclosure Form collectively constitute the "Design Documents". The Design Documents must be submitted in compliance with the specific procedure and by the deadline shown on the FSH website.

C5.8.2 The Design Documents (Report, Specification Sheet and Student Activity Disclosure Form) must be submitted as 3 separate files.

C5.8.3 Document submission will be acknowledged either on the competition website or by email. Teams should have a printed copy of this acknowledgement available at the competition as proof of submission in the event of discrepancy.

**C5.9 Penalty for Late Submission or Non-submission**

The Design Report, Design Spec Sheet and Student Activity Disclosure Form collectively constitute the “Design Documents”. Late submission or failure to submit all, or any one, of the Design Documents will be penalized at the standard negative ten (-10) points per day to a maximum of negative one hundred (-100) points. If any or all of your Design Documents are received more than ten (10) days late they will be classified as “Not Submitted” and your team will receive zero (0) points for Design towards the overall score and may not participate in the Design Event. See also A8.5.

However such entrants may be judged like any other at the event in the Design competition and will receive the same feedback. At the sole discretion of the Design Event Head Judge such entrants may receive a grading indicating their potential had they in fact submitted the Design Documents by the deadline.

Note that teams that receive any such official judging or feedback from the judges will be deemed to have “competed” at the event and as such this may affect their entry eligibility for the following year, see also A6.9 and C5.16

**C5.10 Penalty for Unsatisfactory Submissions**

At the discretion of the judges, teams that submit a Design Report or a Design Spec Sheet which, in the opinion of the judges does not represent a serious effort to comply with the requirements of Rules C5.2, C5.3, C5.4 C5.5 and C5.6 will also not compete in the Design event, but may at the design judges’ discretion receive between five (5) and twenty (20) points for their efforts.

**C5.11 Design Event - Vehicle Condition**

C5.11.1 Cars must be presented for design judging in finished condition, i.e. fully assembled, complete and ready-to-run.

C5.11.2 The judges may not evaluate any car that is presented at the design event in what they consider to be an unfinished state.

C5.11.3 Unfinished cars that are refused judging will receive zero (0) points for design.

C5.11.4 Point penalties may be assessed for cars with obvious preparation issues, e.g. notably loose or missing fasteners.

**Note:** Cars can be presented for design judging without having passed technical inspection, and even if final tuning and setup is in progress.

**C5.12 Judging Criteria**

C5.12.1 The design judges will evaluate the engineering effort based upon the team’s Design Report, Design Spec Sheet, Student Activity Disclosure Form, responses to questions and an inspection of the car.

C5.12.2 The design judges will inspect the car to determine if the design concepts are adequate and appropriate for the application (relative to the objectives set forth in the rules). In addition they will evaluate the team’s understanding and knowledge.

C5.12.3 It is the responsibility of the judges to deduct points if the team cannot adequately explain the engineering and construction of the car.

**C5.13 Judging Sequence**

- C5.13.1 The actual format of the design event may change from competition to competition and year to year as determined by the organizing body.
- C5.13.2 All Formula SAE organizing bodies reserve the right to organize Design Judging into one, two or three steps at their sole discretion.
- C5.13.3 At Formula Student Hungary Engineering Design Judging will be held in the teams pits, the judging schedule will be posted on the FSH home page. The design event will feature on round.

**C5.14 Scoring**

- C5.14.1 Scoring may range from 0 to 150 points at the judge's discretion.
- C5.14.2 The judges may at their discretion award the highest placing team less than 150 points.

**C5.15 Support Material**

Teams may bring with them to the Design Event any photographs, drawings, plans, charts, example components or other materials that they believe are needed to support the presentation of the vehicle and the discussion of their development process.

**C5.16 Second Year Cars - Penalties for Insufficient Redesign**

Not applicable to Formula Student Hungary as Second Year Vehicles are not permitted.

**C5.17 Design Judging Restriction on Team Member Numbers**

- C5.171 Space limitations at the event may require the number of team (student) personnel at the judging session to be limited. If this is the case all teams will be notified in advance, e.g. at the Briefing or in any additional instructions.

Note: this does not prohibit an exchange of team members during the judging session, e.g. engine expert can swap places with suspension expert. The intent here is to avoid overcrowding and to allow judges space to work effectively.

## **FSH Appendix C1 - Sustainability - Powertrain assemblies**

The 2012 Formula Student Hungary Sustainability Report must include as appropriate the list assemblies/parts outlined below which form the powertrain.

- Air Filter
- Carburettor
- Coolant Lines Engine
- Engine Mounts
- Engine/Diff Oil
- Exhaust Manifold
- Fuel Filter
- Fuel Injectors
- Fuel Lines/Rails
- Fuel Pressure Reg.
- Fuel Pump
- Fuel Tank
- Fuel Vent/Check Valve
- Hose Clamps
- Ignition Coil / Wires
- Intake Manifold
- Muffler
- Oil Cooler
- Overflow Bottles
- Radiator
- Radiator Fans
- Restrictor
- Shields
- Sprocket/Pulleys
- Throttle Body
- Turbo/Super Charger
- Mechanical Accumulator (Flywheel/hydraulic)
- Energy Storage (Battery/Capacitor)
- ECM/Engine Electronics/ AMS
- Wire Harness/Connectors
- Fuel Cell
- Accumulator (Battery/Capacitor)
- Accumulator Storage Container
- Electric Motor(s)
- Power Controller
- HV Harness

## 2012 Formula Student Hungary Rules

### PART D - DYNAMIC EVENT REGULATIONS

- ARTICLE 1: DYNAMIC EVENTS AND MAXIMUM SCORES - as per 2012 FSAE Rules**
- ARTICLE 2: WEATHER CONDITIONS - as per 2012 FSAE Rules**
- ARTICLE 3: RUNNING IN RAIN - as per 2012 FSAE Rules**
- ARTICLE 4: DRIVER LIMITATIONS - as per 2012 FSAE Rules**
- ARTICLE 5: ACCELERATION EVENT - as per 2012 FSAE Rules**
- ARTICLE 6: SKID-PAD EVENT - as per 2012 FSAE Rules**
- ARTICLE 7: AUTOCROSS EVENT (known and SPRINT EVENT) - as per 2012 FSAE Rules**
- ARTICLE 8: ENDURANCE AND FUEL ECONOMY - as per 2012 FSAE Rules except for the following**
- D8.4 Endurance Objective—300 points**  
The Endurance Event is designed to evaluate the overall performance of the car and to test the car's durability and reliability.
- D8.5 Fuel Economy / CO<sub>2</sub> Emissions —100 points**
- D8.5.1** For all vehicles, the fuel consumption of the cars during the endurance event will be measured and this number will be converted to a figure representing CO<sub>2</sub> released to the atmosphere. The winner of the fuel economy / CO<sub>2</sub> emissions event will be the car that released the least CO<sub>2</sub>.
- D8.9 Endurance Fuel Fill**
- D8.9.1** For liquid filled vehicles, before entering the event each vehicle's fuel tank must be filled to the fuel level line (see Rule B - 9.6.6, "Fuel Level Line") at the fuelling station. During fuelling, once filled to the scribe line, no shaking or tilting of the tank or fuel system (incl. entire vehicle) is allowed.
- D8.9.2** For electric powered or electric hybrid vehicles, the energy used during the endurance event will be determined by measuring the electrical energy that is used on the DC bus.
- D8.9.3** Regenerative Braking - for electric vehicles using regenerative braking, any recharging of the battery will be accounted for at a rate of 0.9 times the measured recharge energy. Note: This factor is to account for losses in the charge / discharge process that will not be measured by the energy meter.
- D8.18 Endurance Scoring**
- D8.18.1** The score for the Endurance Event is the sum of the Endurance Time Score and the Endurance Finish Score.

- D8.18.2 The Endurance Time Score is based on the team's time for the event, including penalties, compared to the fastest team.
- D8.18.3 A car will also receive an Endurance Finish Score of fifty (50) points if the team's time for the event, including penalties, is less than or equal to the maximum allotted time.

**D8.19 Endurance Scoring Formula**

- D8.19.1 The times for the endurance event will be based upon the sum of the times of each driver in the heat plus penalties.
- D8.19.2 The following equation is used to determine the time scores for the event: If **T<sub>your</sub>** is < or = to **T<sub>max</sub>** :

$$\text{ENDURANCE SCORE} = 250 \times \frac{(\text{T}_{\text{max}}/\text{T}_{\text{your}}) - 1}{(\text{T}_{\text{max}}/\text{T}_{\text{min}}) - 1} + 50$$

If **T<sub>your</sub>** > **T<sub>max</sub>**: ENDURANCE SCORE = 0 (ZERO)

**T<sub>min</sub>** will be the lowest corrected time of the fastest team of the event.

**T<sub>your</sub>** will be the combined corrected times of both of your team's drivers in the heat.

***T<sub>max</sub>** will be 1.45 times **T<sub>min</sub>**.*

- D8.19.3 If, in the opinion of the officials, course conditions change significantly during the running of the event then they may, at their sole discretion, set **T<sub>max</sub>** to a higher value.

**D8.20 Fuel Economy / CO<sub>2</sub> emissions**

The Fuel Economy score is based on the average kg CO<sub>2</sub> per kilometer obtained during the endurance heat.

Teams are advised that the fuel economy score is based only on the distance cars run on the course during the endurance event. Although the starting line, exit line and the driver change zone increase the actual distance a car must drive during the event, those distances are not factored into the fuel economy calculations. Additionally fuel consumption adjustments will not be made for engine running in the entry/exit lines, during driver change, in the penalty box or for any on-course incidents.

**D8.21 CO<sub>2</sub> Conversion Factors**

The mass of CO<sub>2</sub> released to the atmosphere will be assessed by using the conversion factors below from quantity of fuel used to CO<sub>2</sub> released. The factors are intended to represent the average UK supply of the appropriate commodity and the organisers will not take account of where the actual fuel used came from.

Unleaded petrol - 2.3 kg of CO<sub>2</sub> per litre  
Electric - 0.65 kg of CO<sub>2</sub> per kWh  
E85 - 1.64 kg of CO<sub>2</sub> per litre

Note: the Electric energy value includes the anticipated charging losses if the pack is charged over 2hours.

**D8.22 Fuel Economy / CO<sub>2</sub> Emissions Scoring Formula**

*D8.22.1* If CO<sub>2</sub>your is less than CO<sub>2</sub>max then the following equation will be used to determine the fuel economy/CO<sub>2</sub> emissions score:

$$\text{FUEL ECONOMY SCORE} = 100 \times \left( \frac{(\text{CO}_2 \text{ max} - \text{CO}_2 \text{ your})}{(\text{CO}_2 \text{ max} - \text{CO}_2 \text{ min})} \right)$$

If Vyour is greater than Vmax then the following equation will be used to determine a negative fuel economy score:

$$\text{FUEL ECONOMY SCORE} = -100 \times \left( \frac{(\text{CO}_2 \text{ your} / \text{CO}_2 \text{ max}) - 1}{0.33} \right)^{1.5}$$

Where:

CO<sub>2</sub>max is the mass of CO<sub>2</sub> that is emitted to atmosphere and is equivalent to consumption of petrol at 26 liters/ 100 km. Note - For an Endurance Event distance of exactly 22 km, CO<sub>2</sub>max is 13.16kg CO<sub>2</sub>min is the smallest volume of fuel used by any competitor CO<sub>2</sub>your is the volume of fuel used by the team being scored

- D8.22.2 Vehicles where CO<sub>2</sub> emissions exceed CO<sub>2</sub>max by 33% will score negative one hundred (-100) points.
- D8.22.3 Vehicles whose corrected time exceeds 1.45 times the corrected time of the fastest team, will receive zero (0) points for fuel economy.
- D8.22.4 For shortened courses, CO<sub>2</sub>min will be the low value per heat.
- D8.22.5 Fuel economy scores can range from negative one hundred (-100) to positive one hundred (100) points.
- D8.22.6 The minimum combined score for the endurance and fuel economy event will be zero (0) points.

**ARTICLE 9: FLAGS - as per 2012 FSAE Rules**

**ARTICLE 10: RULES OF CONDUCT - as per 2012 FSAE Rules**

**D10.1 Competition Objective - A Reminder**

The Formula Student Hungary event is a design engineering competition that requires performance demonstration of vehicles and is NOT a race. Engineering ethics will apply. It is recognized that hundreds of hours of labour have gone into fielding an entry into Formula SAE. It is also recognized that this event is an "engineering educational experience" but that it often times becomes confused with a high stakes race. In the heat of competition, emotions peak and disputes arise. Our officials are trained volunteers and maximum human effort will be made to settle problems in an equitable, professional manner.

**D10.2 Unsportsmanlike Conduct**

In the event of unsportsmanlike conduct, the team will receive a warning from an official. A second violation will result in expulsion of the team from the competition.

**D10.3 Official Instructions**

Failure of a team member to follow an instruction or command directed specifically to that team or team member will result in a twenty five (25) point penalty.

**Note:** This penalty can be individually applied to all members of a team.

**D10.4 Arguments with Officials**

Argument with, or disobedience to, any official may result in the team being eliminated from the competition. All members of the team may be immediately escorted from the grounds.

**D10.5 Alcohol and Illegal Material**

D10.5.1 Alcohol, illegal drugs, weapons or other illegal material are prohibited on the event site during the competition. This rule will be in effect during the entire competition.

D10.5.2 Any violation of this rule by a team member will cause the expulsion of the entire team. This applies to both team members and faculty advisors.

D10.5.3 Any use of drugs, or the use of alcohol by an underage individual, will be reported to the local authorities.

**D10.6 Parties**

In the interest of responsible citizenship it is expected that any disruptive parties, either on or off-site, will be prevented by the Faculty Advisor.

**D10.7 Trash Clean-up**

D10.7.1 Cleanup of trash and debris is the responsibility of the teams. The team's work area should be kept uncluttered. At the end of the day, each team must clean all debris from their area and help with maintaining clean and tidy garages.

D10.7.2 Teams are required to ensure that all of their material and trash is cleared away in a proper manner when leaving the site at the end of the competition. Teams that abandon furniture, or that leave a garage that requires special cleaning, will be billed for removal and/or cleanup costs.

**D10.8 Additional Conduct Rules**

Specific rules and regulations applicable to the Formula Student Hungary event will be issued to all competitors prior to the event, which must be read fully by all team members.

**D10.9 Advertising Regulations**

To ensure full compliance with UK and European legislation, teams are not permitted to display any form of tobacco or cigarette advertising on their vehicles or display areas. The organisers also reserve the right to instruct teams to remove or cover any other vehicle or display area markings that may be illegal or likely to cause offence.

**D10.10 Future Exclusion From Formula Student Hungary**

In addition, the organisers hereby reserve the right to deduct points, or exclude individuals or teams from future competitions, if they act in such a way, at any time, as to actually or potentially bring the Formula Student name into disrepute.

Teams or individuals associated with them, displaying and/or running their vehicles at any events organised by themselves or others, who use the Formula Student name while doing so, and act irresponsibly or recklessly, may, at the organiser's sole discretion, be deemed to have acted in breach of this rule.

**D10.11 Considerations When Testing Your Vehicle**

Teams are reminded that cars built according to the Formula SAE and Formula Student Hungary rules are not designed or intended for racing or use at high speed, or in confined areas where they might impact with solid objects, including safety barriers. Teams are advised to develop and run their vehicles on large, substantially open areas, and to do so only under similar speed and cornering conditions as they would face at official FSAE or FSH events. It is further advised that all cars are checked by an official scrutineer - a list of all approved MSA scrutineers in the UK, who can be contacted, is available from the Operations Co-ordinator (Neil Carr-Jones, 01483 524400).

**ARTICLE 11: GENERAL RULES - as per 2012 FSAE Rules**

**ARTICLE 12: PROTESTS - as per 2012 FSAE Rules**

**ARTICLE 13: PIT RULES - as per 2012 FSAE Rules**

**ARTICLE 14: DRIVING RULES - as per 2012 FSAE Rules**

**ARTICLE 15: DEFINITIONS - as per 2012 FSAE Rules**